

Data sheet

Solenoid valve

Type EVR 2 - EVR 40 Version 2

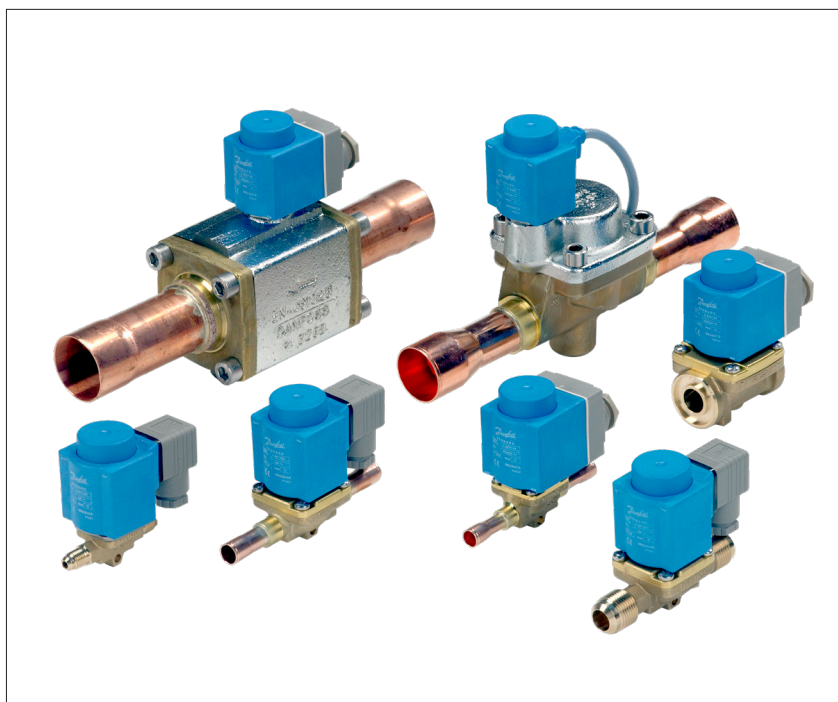

EVR is a direct or servo operated solenoid valve suitable for liquid, suction, and hot gas lines with most refrigerants, including flammable refrigerants.

EVR valves and coils are sold separately.

Features

- Complete range of solenoid valves for refrigeration, freezing and air conditioning plant
- Supplied in versions normally closed (NC) and normally open (NO) with de-energized coil
- Wide choice of coils for AC and DC • Suitable for most refrigerants, including flammable refrigerants
- Designed for media temperatures up to 105 °C
- Flare connections up to 5/8 in • Solder connections up to 2 1/8 in • Extended ends on solder versions make the installation easy, eliminating the need to dismantle the valve when soldering in
- Available in flare, solder and flange connection versions

Approvals

- Pressure Equipment Directive (PED) 2014/68/EU
- Low Voltage Directive (LVD) 2014/35/EU
- UL429 General Purpose Valve
- EAC
- UA
- ATEX zone 2
- CQC
- RoHS II
- For Marine approvals: Contact Danfoss for latest updates

Table of contents	
Technical data	3
Rated capacity [kW]	4
Ordering	5
EVR solder connection (NC)	5
EVR solder connection (NO)	6
EVR flare connection (NC)	6
EVR flare connection (NO)	6
EVR flange connection (NC)	7
EVRC solder connection (NC)	7
Function	8
Design and material specifications	9
EVR 2 - EVR 3 solder and flare connection	9
EVR 4 - EVR 6 - EVR 8 solder and flare connection	10
EVR 10 solder and flare connection	11
EVR 15 - EVR 18 solder, flare and flange connection	12
EVR 20 - EVR 22 solder and flange connection	13
EVR 25 solder connection	14
EVR 32 - EVR 40 solder connection	15
EVRC solder connection	16
Dimensions and weights	17
EVR 2 - EVR 3 solder connection	17
EVR 4 - EVR 6 - EVR 8 solder connection	18
EVR 10 solder connection	19
EVR 15 - EVR 18 solder connection	20
EVR 20 - EVR 22 solder connection	21
EVR 25 solder connection	22
EVR 32 - EVR 40 solder connection	23
EVRC 15 solder connection	24
EVRC 20 solder connection	25
EVR 2 - EVR 3 flare connection	26
EVR 6 flare connection	27
EVR 10 flare connection	28
EVR 15 flare connection	29
EVR 15 flange connection	30
EVR 20 flange connection	31
Extended capacity, Liquid	32
Extended capacity, Suction	35
Extended capacity, Hot gas	47

Technical data
Refrigerants

R22/R407C, R134a, R404A/R507, R410A, R407A, R32, R290, R600, R600a, R1234yf, R1234ze, R404A, R407F, R407H, R125, R152A, R448A, R449A, R452A, and R450A.

For a complete list of approved refrigerants, visit www.products.danfoss.com and search for individual code numbers, where refrigerants are listed as part of technical data.

Special note for R152A, R32, R290, R600, R600a, R1234yf, and R1234ze:

This product is validated in accordance to ATEX, ISO 5149, IEC 60335, and UL. Ignition risk is evaluated in accordance to ISO 5149 and IEC 60335.

See safety note at the bottom of this page.

Media temperature

-40 – 105 °C

Max. 130 °C during defrosting

Ambient temperature and enclosure for coil

See separate data sheet for solenoid and ATEX coils.

Max. working pressure

EVR solder and flare connections: 45.2 bar.

EVR flange connections: 32 bar.

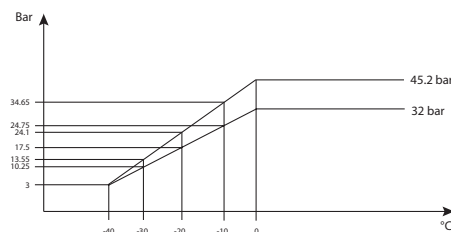

Max. working pressure in bar in relation to media temperature in °C.

Capacity

See K_v values from the table.

The K_v value is the water flow in [m³/h] at a pressure drop across valve of 1 bar, $\rho = 1000 \text{ kg/m}^3$.

See extended capacity tables later in this data sheet.

Type	Opening differential pressure with standard coil Δp [bar]		
	Min.	Max. (= MOPD) liquid	
		AC coil [10 W]	DC coil [20 W]
EVR 2 NC	0.00	38	33
EVR 3 NC	0.00	38	18
EVR 4 NC	0.03	38	28
EVR 6 NC	0.03	38	28
EVR 6 NO	0.03	21	21
EVR 8 NC	0.03	38	28
EVR 10 NC	0.03	38	20
EVR 10 NO	0.03	21	21
EVR 15 NC	0.03	38	20
EVR 15 NO	0.03	21	21
EVR 18 NC	0.03	38	20
EVR 20 NC	0.03	38	20
EVR 20 NO	0.03	19	19
EVR 22 NC	0.03	38	20
EVR 22 NO	0.03	19	19
EVR 25 NC	0.20	38	17
EVR 32 NC	0.20	38	17
EVR 40 NC	0.20	38	17

For higher MODP 12 W and 20 W AC coils are available on request



The EVR 2 - EVR 22 with solder connections and without manual stem can be applied on systems with R152A, R32, R290, R600, R600a, R1234yf, and R1234ze as the working fluid.

For countries where safety standards are not an indispensable part of the safety system Danfoss recommends the installer gets a third party approval of any system containing flammable refrigerant.

Note: please follow specific selection criteria stated in the datasheet for these particular refrigerants.

Data sheet | Solenoid valve, types EVR 2 - EVR 40 Version 2

**Rated capacity [kW]
For other refrigerants, refer
to Coolselector®2**

Type	R22/R407C	R134a	R404A/R507	R410A	R32	R290	R600a
Liquid							
EVR 2	3.02	2.79	2.04	2.96	4.23	3.36	3.38
EVR 3	5.43	5.02	3.68	5.32	7.61	6.05	6.09
EVR 4	13.68	12.66	9.26	13.41	19.17	15.23	15.33
EVR 6	17.90	16.56	12.12	17.55	25.09	19.93	20.07
EVR 8	21.32	19.73	14.44	20.90	29.88	23.74	23.90
EVR 10	37.62	34.80	25.47	36.88	52.71	41.88	42.17
EVR 15	57.93	53.60	39.23	56.79	81.18	64.49	64.94
EVR 18	75.84	70.16	51.36	74.35	106.26	84.43	85.01
EVR 20	120.29	111.29	81.46	117.93	168.56	133.92	134.85
EVR 22	137.19	126.92	92.90	134.49	192.23	152.73	153.79
EVR 25	149.23	138.06	101.06	146.30	-	-	-
EVR 32	254.97	235.89	172.66	249.96	-	-	-
EVR 40	368.74	341.15	249.71	361.49	-	-	-
Suction vapour							
EVR 2	0.33	0.24	0.29	0.42	0.54	0.41	0.23
EVR 3	0.60	0.44	0.52	0.75	0.96	0.73	0.41
EVR 4	1.51	1.10	1.32	1.90	2.43	1.85	1.03
EVR 6	1.98	1.44	1.72	2.48	3.18	2.42	1.35
EVR 8	2.35	1.71	2.05	2.96	3.78	2.88	1.60
EVR 10	4.15	3.02	3.62	5.22	6.67	5.09	2.83
EVR 15	6.40	4.65	5.57	8.03	10.28	7.83	4.36
EVR 18	8.37	6.09	7.30	10.52	13.45	10.26	5.70
EVR 20	13.28	9.66	11.57	16.68	21.34	16.27	9.04
EVR 22	15.15	11.02	13.20	19.02	24.34	18.55	10.31
EVR 25	16.33	11.79	14.25	20.58	-	-	-
EVR 32	27.90	20.14	24.35	35.16	-	-	-
EVR 40	40.35	29.12	35.21	50.85	-	-	-
Hot gas							
EVR 2	1.35	1.04	1.10	1.65	2.18	1.54	0.94
EVR 3	2.42	1.87	1.99	2.98	3.92	2.76	1.70
EVR 4	6.10	4.70	5.01	7.50	9.86	6.96	4.28
EVR 6	7.99	6.16	6.56	9.81	12.91	9.11	5.61
EVR 8	9.51	7.33	7.81	11.68	15.37	10.85	6.68
EVR 10	16.78	12.94	13.78	20.61	27.12	19.14	11.78
EVR 15	25.85	19.93	21.22	31.74	41.77	29.48	18.14
EVR 18	33.84	26.08	27.77	41.55	54.67	38.59	23.75
EVR 20	53.68	41.37	44.05	65.91	86.72	61.21	37.67
EVR 22	61.22	47.18	50.24	75.17	98.91	69.81	42.96
EVR 25	87.87	67.73	72.12	107.91	-	-	-
EVR 32	150.17	115.75	123.24	184.40	-	-	-
EVR 40	217.22	167.43	178.27	266.74	-	-	-

Rated liquid and suction vapor capacity is based on evaporating temperature $t_e = -10\text{ }^\circ\text{C}$, liquid temperature ahead of valve $t_l = 25\text{ }^\circ\text{C}$, pressure drop in valve $\Delta p = 0.15\text{ bar}$.

Rated hot gas capacity is based on condensing temperature $t_c = 40\text{ }^\circ\text{C}$, pressure drop across valve $\Delta p = 0.8\text{ bar}$, hot gas temperature $t_h = 65\text{ }^\circ\text{C}$, and subcooling of refrigerant $\Delta t_{sub} = 4\text{ K}$.

**Ordering
EVR solder connection,
Normally Closed (NC)
- separate valve bodies**

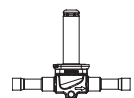

EVR 2 / EVR 3



EVR 4 / EVR 6 / EVR 8

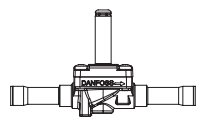

EVR 10



EVR 15 / EVR 18 / EVR 20 / EVR 22

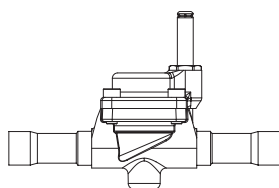

EVR 25

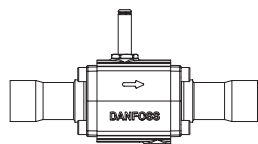

EVR 32 / EVR 40

Type	Coil voltage	Connection size [in]	Connection size [mm]	Manual operation	K _v value [m ³ /h]	Code no.
EVR 2	AC / DC	¼	–	No	0.15	032F1201
	AC / DC	¼	–	No	0.15	032F7100
	AC / DC	–	6	No	0.15	032F1202
EVR 3	AC / DC	¼	–	No	0.26	032F1206
	AC / DC	¾	–	No	0.26	032F1204
	AC / DC	–	6	No	0.26	032F1207
EVR 4	AC / DC	¾	–	No	0.26	032F1208
	AC / DC	–	10	No	0.26	032F1208
	AC / DC	¾	–	No	0.70	032L7110
EVR 6	AC / DC	¾	–	No	1.0	032L1212
	AC / DC	¾	–	Yes	0.87	032L7116
	AC / DC	–	10	No	1.0	032L1213
	AC / DC	–	12	No	1.0	032L1236
	AC / DC	½	–	No	1.0	032L1209
	AC / DC	½	–	Yes	0.87	032L7144
EVR 8	AC / DC	¾	–	No	1.0	032L7117
	AC / DC	½	–	No	1.15	032L7121
	AC / DC	½	–	Yes	1.09	032L7148
EVR 10	AC / DC	¾	–	No	1.15	032L7122
	AC / DC	¾	–	No	1.56	032L7125
	AC / DC	–	12	No	2.2	032L1218
	AC / DC	½	–	No	2.2	032L1217
	AC / DC	½	–	Yes	2.2	032L1188
	AC / DC	¾	16	No	2.2	032L1214
EVR 15	AC / DC	¾	–	Yes	2.2	032L7149
	AC / DC	¾	16	No	3.3	032L1228
	AC / DC	¾	16	Yes	3.3	032L1227
EVR 18	AC / DC	¾	22	No	3.3	032L1225
	AC / DC	¾	–	Yes	3.9	032L1004
	AC / DC	¾	–	No	6.0	032L1240
EVR 20	AC / DC	¾	–	Yes	6.0	032L1254
	AC / DC	1 ½	–	No	6.0	032L1244
	AC / DC	–	28	No	6.0	032L1245
	AC / DC	1 ½	–	No	6.0	032L7145
EVR 22	AC / DC	1 ½	–	Yes	6.0	032L7137
	AC / DC	1 ¾	–	No	6.0	032L3267
	AC / DC	1 ¾	–	Yes	9.8	032L2200
EVR 25	AC / DC	1 ½	–	No	9.8	032L2201
	AC / DC	–	28	Yes	9.8	032L2205
	AC / DC	–	28	No	9.8	032L2206
	AC / DC	1 ¾	–	Yes	9.8	032L2207
	AC / DC	1 ¾	–	No	9.8	032L2208
	AC / DC	1 ¾	–	Yes	9.8	032L2209
EVR 32	AC / DC	1 ¾	35	Yes	16.7	032L1105
	AC / DC	1 ¾	35	No	16.7	032L1106
	AC / DC	1 ¾	–	Yes	16.7	032L1103
	AC / DC	1 ¾	–	No	16.7	032L1104
	AC / DC	–	42	Yes	16.7	032L1107
	AC / DC	–	42	No	16.7	032L1108
EVR 40	AC / DC	2 ½	–	No	16.7	032L1180
	AC / DC	2 ½	–	Yes	16.7	032L1181
	AC / DC	1 ¾	–	Yes	24.2	032L1109
	AC / DC	1 ¾	–	No	24.2	032L1110
	AC / DC	–	42	Yes	24.2	032L1113
	AC / DC	–	42	No	24.2	032L1114
EVR 40	AC / DC	2 ½	–	Yes	24.2	032L1111
	AC / DC	2 ½	–	No	24.2	032L1112
	AC / DC	2 ½	–	No	24.2	032L1112

See separate data sheet for coils

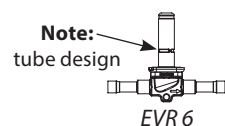
**Ordering
EVR solder connection,
Normally Open (NO)
- separate valve bodies**

Type	Coil voltage	Connection size [in]	Connection size [mm]	Manual operation	K _v value [m ³ /h]	Code no.
EVR 6	AC / DC	3/8	–	No	1.0	032L1290
	AC / DC	–	10	No	1.0	032L1295
EVR 10	AC / DC	1/2	–	No	2.2	032L1291
	AC / DC	–	12	No	2.2	032L1296
EVR 15	AC / DC	3/8	16	No	3.3	032L1299
	AC / DC	7/8	–	No	3.3	032L3270
EVR 20	AC / DC	7/8	–	No	6.0	032L1260
	AC / DC	1 1/8	–	No	6.0	032L1269
	AC / DC	–	28	No	6.0	032L1279
EVR 22	AC	1 3/8	–	No	6.0	032L3268

See separate data sheet for coils

The normal range of coils can be used for the NO valves, with the exception of the double frequency versions of 110 V, 50/60 Hz and 220 V, 50/60 Hz.

**Ordering
EVR flare connection,
Normally Closed (NC)
- separate valve bodies**

Type	Coil voltage	Connection size [in]	Connection size [mm]	Manual operation	K _v value [m ³ /h]	Code no.
EVR 2	AC / DC	1/4	6	No	0.15	032F8056
EVR 3	AC / DC	1/4	6	No	0.26	032F8107
	AC / DC	3/8	10	No	0.26	032F8116
EVR 6	AC / DC	3/8	10	No	1.0	032L8072
	AC / DC	1/2	12	No	1.0	032L8079
EVR 10	AC / DC	1/2	12	No	2.2	032L8095
	AC / DC	3/8	16	No	2.2	032L8098
EVR 15	AC / DC	3/8	16	Yes	3.3	032L8100
	AC / DC	5/8	16	No	3.3	032L8101

See separate data sheet for coils

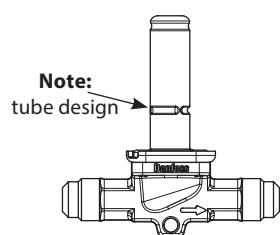
**Ordering
EVR flare connection,
Normally Open (NO)
- separate valve bodies**

Type	Coil voltage	Connection size [in]	Connection size [mm]	Manual operation	K _v value [m ³ /h]	Code no.
EVR 6	AC / DC	3/8	10	No	1.0	032L8085
EVR 10	AC / DC	1/2	12	No	2.2	032L8090

See separate data sheet for coils

The normal range of coils can be used for the NO valves, with the exception of the double frequency versions of 110 V, 50/60 Hz and 220 V, 50/60 Hz.

Valve bodies are supplied without flare nuts.

Separate flare nuts:

– 1/4 in or 6 mm, code no. **011L1101**

– 3/8 in or 10 mm, code no. **011L1135**

– 1/2 in or 12 mm, code no. **011L1103**

– 5/8 in or 16 mm, code no. **011L1167**

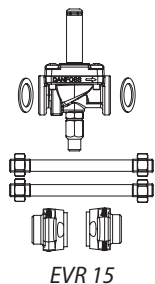
Data sheet | Solenoid valve, types EVR 2 - EVR 40 Version 2
**Ordering
EVR flange connection,
Normally Closed (NC)
- separate valve bodies**

Type	Coil voltage	Connection	Manual operation	Code no.
EVR 15	AC / DC	Flanges	No	032L1224
	AC / DC	Flanges	Yes	032L1234
EVR 20	AC / DC	Flanges	No	032L1243
	AC / DC	Flanges	Yes	032L1253

See separate data sheet for coils

Flange sets

Type	Connection size		Connection type			Code no.
	[in]	[mm]	Solder [in]	Solder [mm]	Weld [in]	
EVR 15	1/2	-	-	-	Yes	027N1115
	3/8	-	Yes	-	-	027L1117
	-	16	-	Yes	-	027L1116
	3/4	-	-	-	Yes	027N1120
	7/8	-	Yes	-	-	027L1123
	-	22	-	Yes	-	027L1122
EVR 20	3/4	-	-	-	Yes	027N1220
	7/8	-	Yes	-	-	027L1223
	-	22	-	Yes	-	027L1222
	1	-	-	-	Yes	027N1225
	1 1/8	-	Yes	-	-	027L1229
	-	28	-	Yes	-	027L1228

See separate data sheet for coils

Example

EVR 15 without manual operation,
code no. **032L1224**

1/2 in weld flange set,
code no. **027N1115**

+ coil with terminal box, 220 V, 50 Hz,
code no. **018F6701**

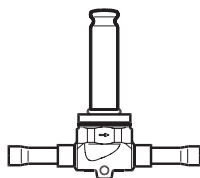
**Ordering
EVRC solder connection,
Normally Closed (NC)
- separate valve bodies**

Type	Coil voltage	Connection size [in]	Connection size [mm]	Manual operation	K _v value [m ³ /h]		Code no.
					Flow in arrow direction	Flow against arrow direction	
EVRC 15	AC / DC	3/8	16	No	2.7	2.5	032L1255
EVRC 20	AC / DC	7/8	22	No	3.6	5.0	032L1258

See separate data sheet for coils.

Function

EVR solenoid valves are designed on two different principles:

1. Direct operation
2. Servo operation

See *Design and material drawings* for additional details on the following pages

1. Direct operation (NC)

EVR 2 – EVR 3 are direct operated. The valves open directly for full flow when the armature (3) moves up into the magnetic field of the coil.

This means that the valves operate with a minimum differential pressure of 0 bar.

The seat plate is fitted directly on the armature (3).

Inlet pressure acts from above on the armature and the valve plate. Thus, the inlet pressure and spring force act to close the valve when there is no current in the coil.

2. Servo operation (NC)

EVR 4 – EVR 22 are servo operated with a "floating" diaphragm (4). The pilot orifice of stainless steel is placed in the center of the diaphragm. The seat plate is fitted directly to the armature (3). When there is no current in the coil, the main orifice and pilot orifice are closed. The pilot orifice and main orifice are held closed by the armature spring force and the differential pressure between inlet and outlet sides.

When current is applied to the coil, the armature is drawn up into the magnetic field and opens the pilot orifice. This relieves the pressure above the diaphragm, i.e. the space above the diaphragm becomes connected to the outlet side of the valve.

The differential pressure between inlet and outlet sides then presses the diaphragm away from the main orifice and opens it for full flow. Therefore a certain minimum differential pressure is necessary to open the valve and keep it open. For EVR 4 – EVR 22 valves the minimum differential pressure for safe operation is 0.03 bar.

When the current is switched off, the pilot orifice is closed. Via the equalization holes in the diaphragm, the pressure above the diaphragm rises to the same value as the inlet pressure and the diaphragm closes the main orifice.

EVR 25, EVR 32 and EVR 40 are servo operated piston valves. The servo piston (16) with sealing face closes against the valve seat by means of the differential pressure between inlet and outlet side of the valve and the force of the compression spring. When the coil is switched on, the pilot orifice opens. This relieves the pressure on the piston spring side of the valve. The differential pressure will then open the valve. The minimum differential pressure for safe operation is 0.2 bar.

EVR (NO) has the opposite function to EVR (NC), i.e. it is open with de-energized coil.

EVR (NO) is available with servo operation only.

3. Bi-flow operation with EVRC

EVRC is a servo operated solenoid valve with a special diaphragm with built-in non-return valve. The valve is for use in liquid lines in refrigeration plants.

EVRC allows flow in both directions and can be used in liquid lines in refrigeration plants with hot gas or gas defrost.

During the refrigeration period EVRC works as a normal solenoid valve, while during defrost it allows the condensed liquid to return to the liquid manifold.

During the defrosting period the coil for EVRC must be energized.

4. Manual stem operation for EVR 6 - EVR 25 NC

EVR 6 - EVR 25 NC are available with optional manual stem operation to manually force the NC valve open when the coil is de-energized.

The protective cap should be removed and the manual stem (12) should be rotated until the valve is fully open. It takes approx. 6 cycles from fully closed, to reach the fully open position.

After manual operation is completed, the valve should manually be closed again and the protective cap mounted.

Alternatively, all EVR NC and NO valves can be manually operated by removing the coil and force the valve open or closed by using a solenoid valve tester (permanent magnet) code no. 018F0091.

Design and material specifications

**EVR 2 - EVR 3
Solder and flare connection**

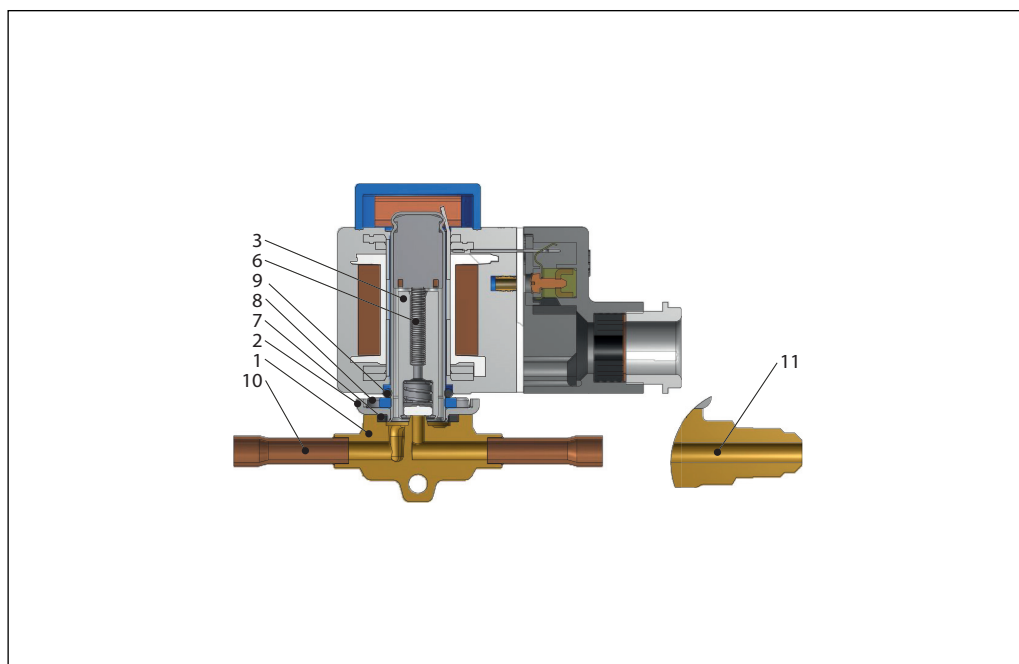

Pos. no.	Description	Material
1	Valve assembly housing	Brass, copper
2	Cover assembly	Stainless steel
3	Armature assembly	Stainless steel/PTFE
6	Armature spring	Stainless steel
7	Seal	Chloroprene rubber
8	Screw	Stainless steel
9	O-ring	EPDM Rubber
10	Solder connection	Copper
11	Flare connection	Brass

Design and material specifications

**EVR 4 - EVR 6 - EVR 8
Solder and flare connection**

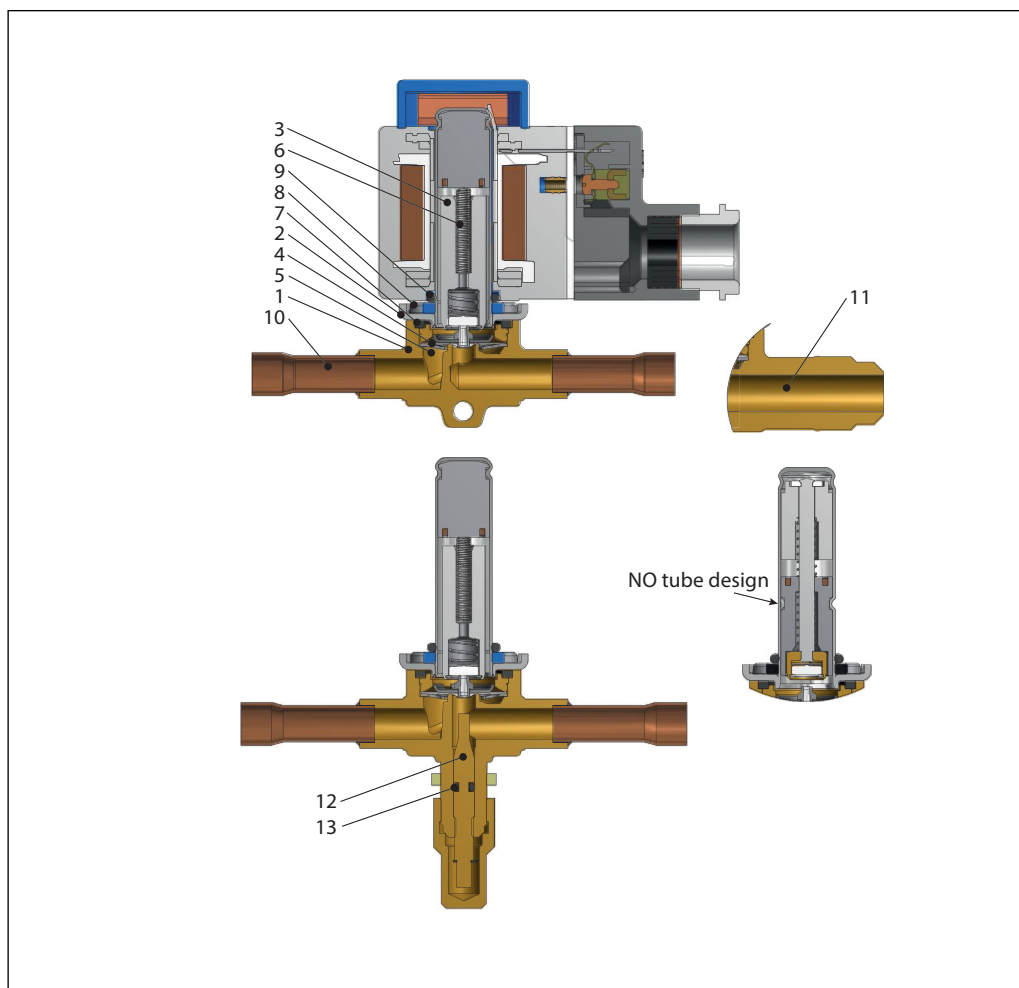

Pos. no.	Description	Material
1	Valve housing assembly	Brass
2	Cover	Stainless steel
3	Armature assembly	Stainless steel/PTFE
4	Diaphragm assembly	Stainless steel/PTFE
5	Support washer	Stainless steel
6	Armature spring	Stainless steel
7	Seal	Chloroprene rubber
8	Screws	Stainless steel
9	O-ring	EPDM rubber
10	Solder connection	Copper
11	Flare connection	Brass
12	Manual stem ¹⁾	Brass
13	O-ring	Chloroprene rubber

¹⁾ Manual stem is not available for EVR 4

Design and material specifications

**EVR 10
Solder and flare connection**

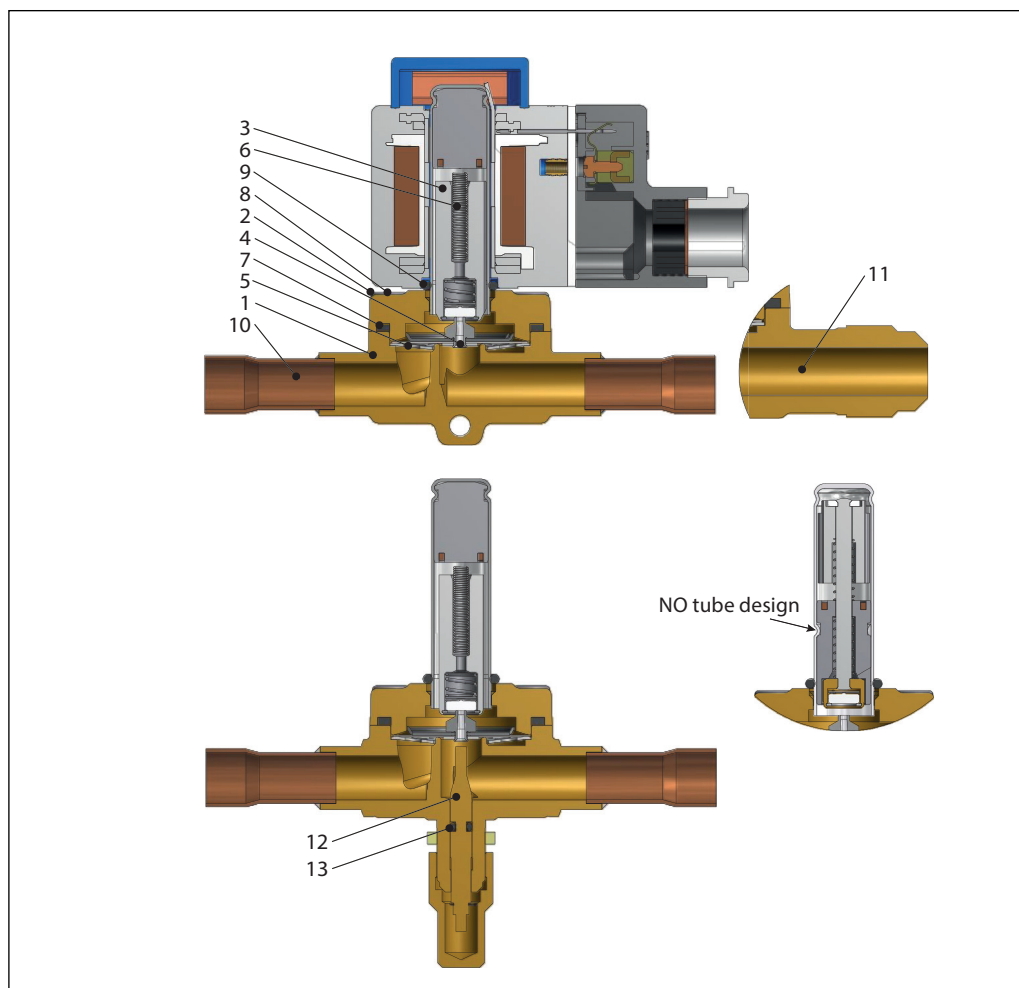

Pos. no.	Description	Material
1	Valve body	Brass
2	Cover	Brass
3	Armature assembly	Stainless steel/PTFE
4	Diaphragm assembly	Stainless steel/PTFE
5	Support washer	Stainless steel
6	Armature spring	Stainless steel
7	Seal	Chloroprene rubber
8	Screws	Stainless steel
9	O-ring	EPDM rubber
10	Solder connection	Copper
11	Flare connection	Brass
12	Manual stem	Brass
13	O-ring	Chloroprene rubber

Design and material specifications

EVR 15 - EVR 18
Solder, flare, and flange connection

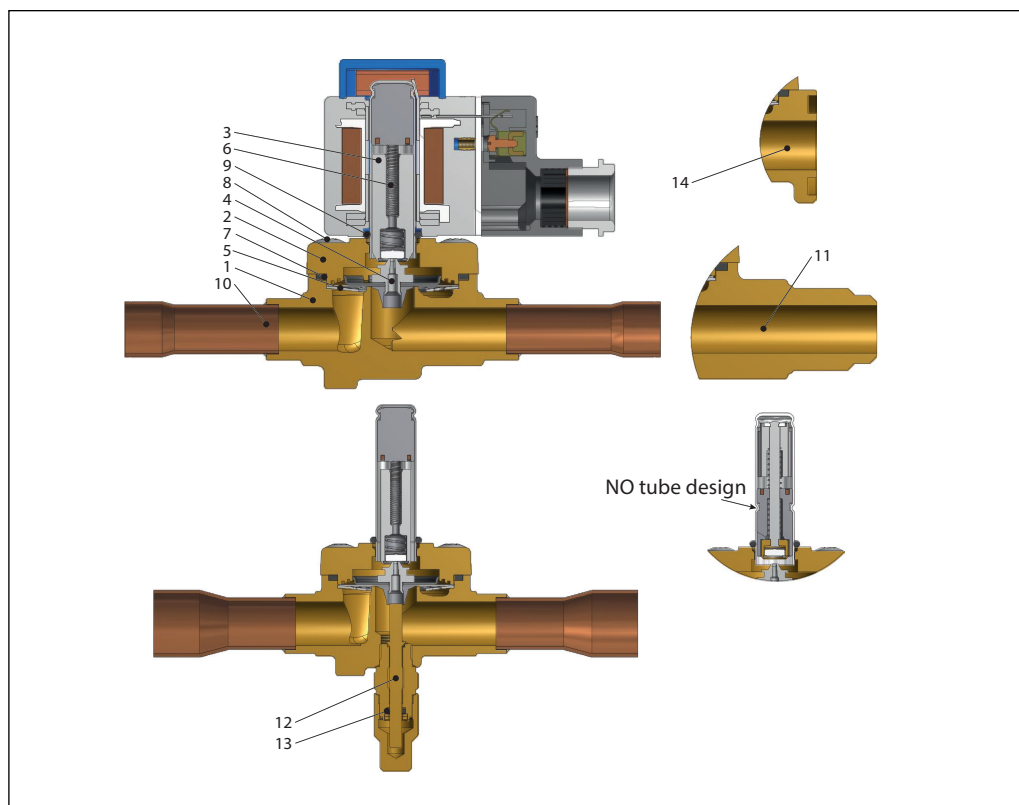

Pos. no.	Description	Material
1	Valve body	Brass
2	Cover	Brass
3	Armature assembly	Stainless steel/PTFE
4	Diaphragm assembly	Stainless steel/PTFE
5	Support washer	Stainless steel
6	Armature spring	Stainless steel
7	Seal	Chloroprene rubber
8	Screws	Stainless steel
9	O-ring	EPDM rubber
10	Solder connection	Copper
11	Flare connection	Brass
12	Manual stem	Brass
13	O-ring	Chloroprene rubber
14	Flange connection	Brass

Design and material specifications

**EVR 20 - EVR 22
Solder and flange connection**

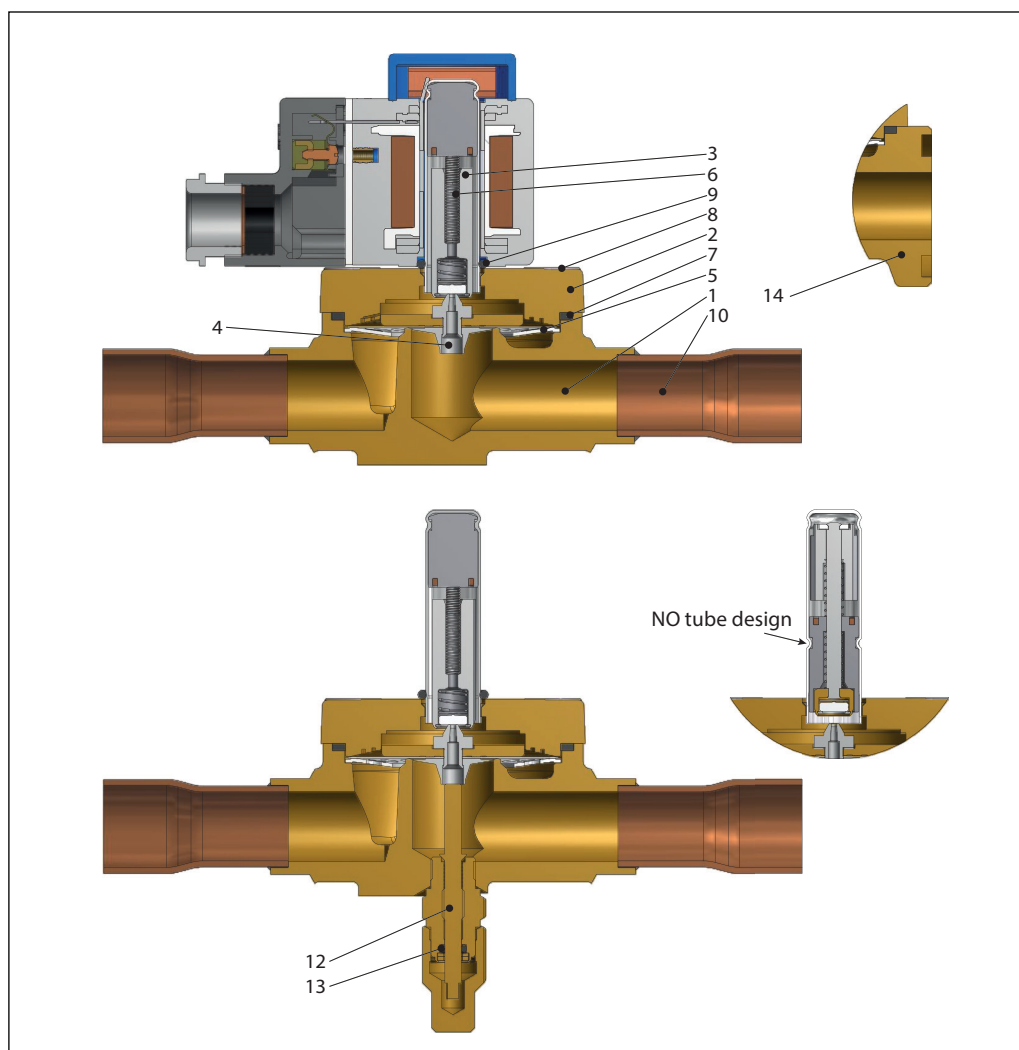

Pos. no.	Description	Material
1	Valve body	Brass
2	Cover	Brass
3	Armature assembly	Stainless steel/PTFE
4	Diaphragm assembly	Stainless steel/PTFE
5	Support washer	Stainless steel
6	Armature spring	Stainless steel
7	Seal	Chloroprene rubber
8	Screws	Stainless steel
9	O-ring	EPDM rubber
10	Solder connection	Copper
12	Manual stem	Brass
13	O-ring	Chloroprene rubber
14	Flange connection	Brass

Design and material specifications

EVR 25
Solder connection

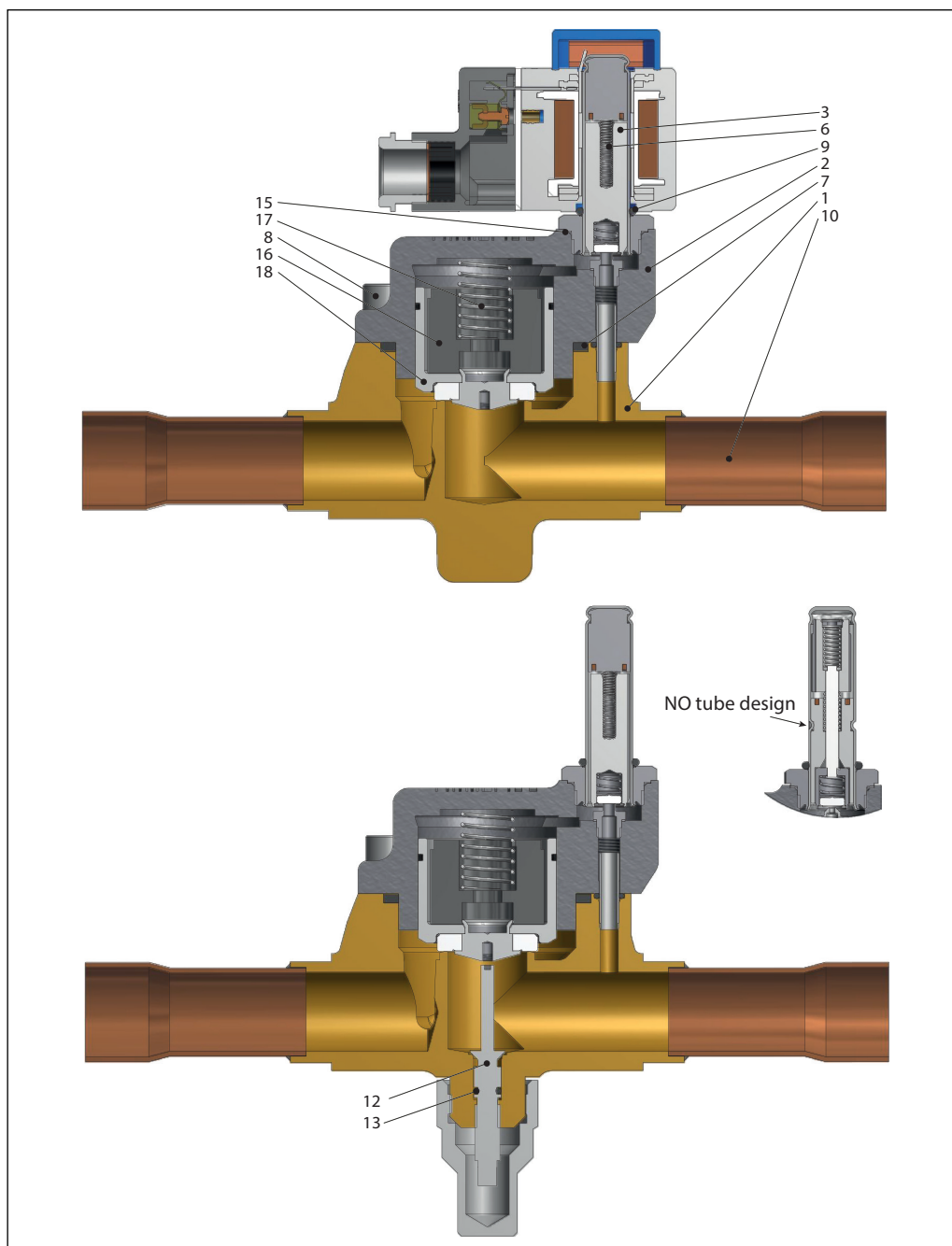

Pos. no.	Description	Material
1	Valve body	Brass
2	Cover	Cast iron
3	Armature assembly	Stainless steel/PTFE
6	Armature spring	Stainless steel
7	Gasket	Chloroprene rubber
8	Screws	Stainless steel
9	O-ring	EPDM rubber
10	Solder connection	Copper
12	Manual stem	Brass
13	O-ring	Chloroprene rubber
15	Gasket	Aluminum
16	Insert	Nylon
17	Piston spring	Stainless steel
18	Piston	Stainless steel

Design and material specifications

EVR 32 - EVR 40
Solder connection

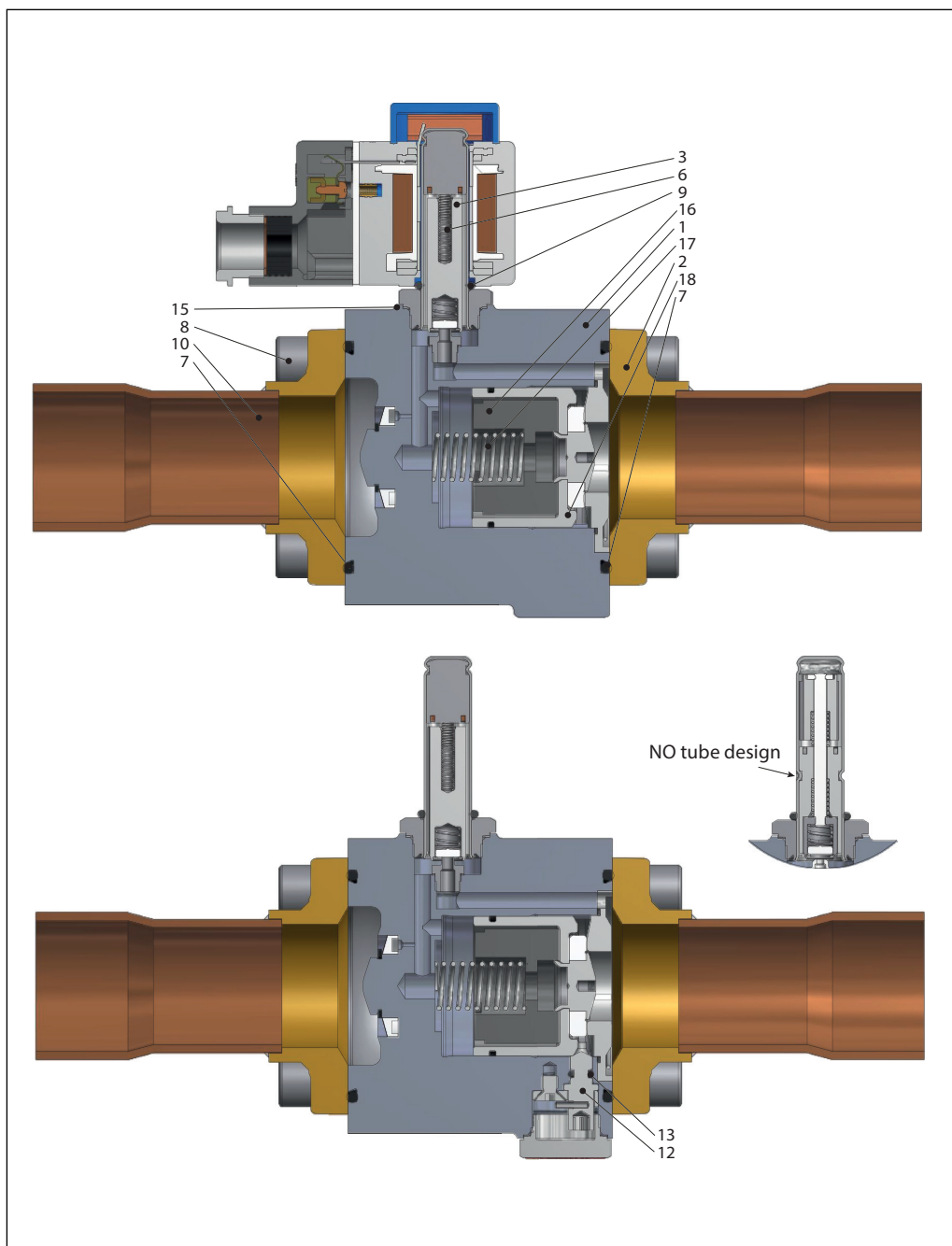

Pos. no.	Description	Material
1	Valve body	Cast iron
2	Cover	Brass
3	Armature assembly	Stainless steel
6	Armature spring	Stainless steel
7	Gasket	Chloroprene rubber
8	Screws	Stainless steel
9	O-ring	EPDM rubber
10	Solder connection	Copper
12	Manual stem	Brass
13	O-ring	Chloroprene rubber
15	Gasket	Aluminum
16	Insert	Nylon
17	Piston spring	Stainless steel
18	Piston	Stainless steel

Design and material specifications

EVRC
Solder connection

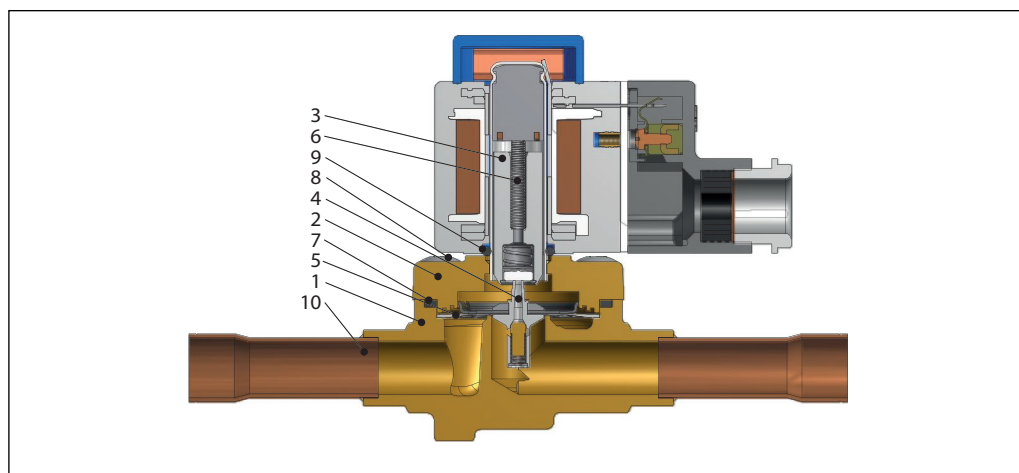

Pos. no.	Description	Material
1	Valve body	Brass
2	Cover	Brass
3	Armature assembly	Stainless steel/PTFE
4	Diaphragm assembly	Stainless steel/PTFE
5	Support washer	Stainless steel
6	Armature spring	Stainless steel
7	Gasket	Chloroprene rubber
8	Screws	Stainless steel
9	O-ring	EPDM rubber
10	Solder connection	Copper

Dimensions and weights

EVR 2 - EVR 3
Solder connection

Cable coil¹⁾

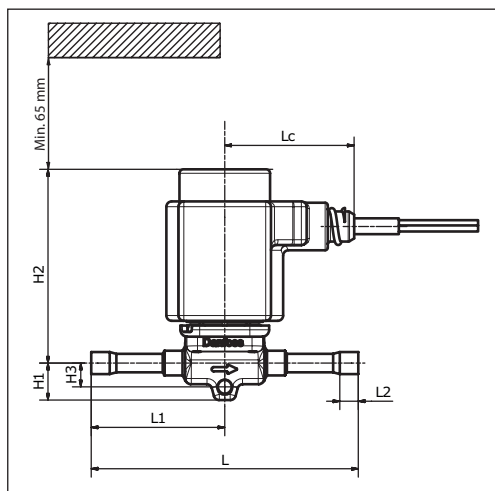

DIN plug coil²⁾

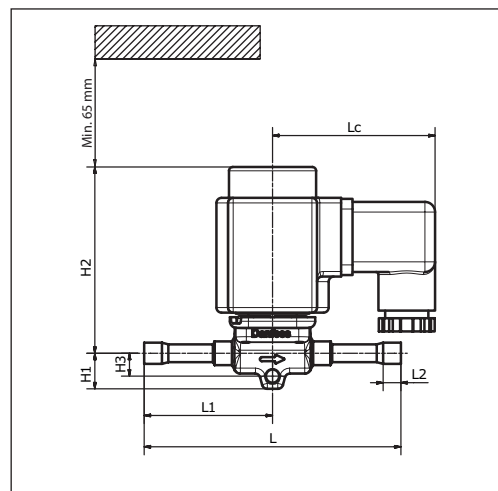

Terminal box coil³⁾

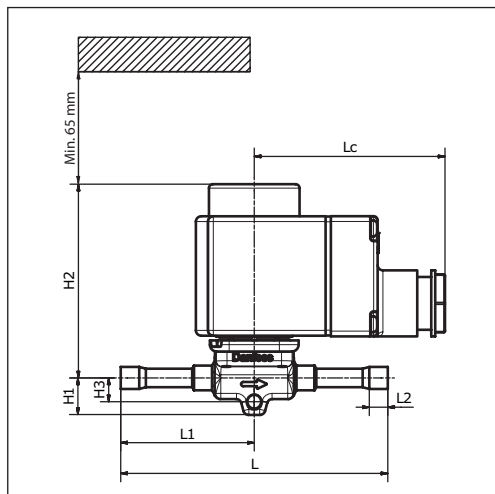

End view

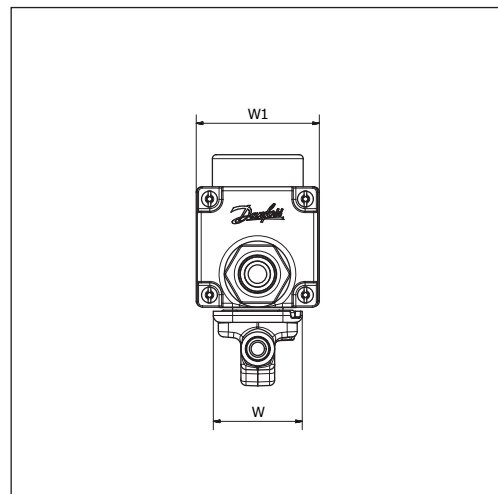

Type	Connection		H ₁ [mm]	H ₂ [mm]	H ₃ [mm]	L [mm]	L ₁ [mm]	L ₂ [mm]	L _c [mm]	W [mm]	W ₁ max. [mm]	Net weight without coil [kg]	
	[in]	[mm]											
EVR 2	1/4	6	14	73	9	101	50.5	7	–	34	–	0.16	
EVR 3	1/4	6	14	73	9	101	50.5	7	–	34	–	0.16	
	3/8	10	14	73	9	117	58.5	8	–	34	–	0.17	
Cable coil ¹⁾										49	–	46	–
DIN plug coil ²⁾										64	–	47	–
Terminal box coil 10 W ³⁾										72	–	47	–
Terminal box coil 12 / 20 W ³⁾										80		68	

Net weight of coil
10 W: approx. 0.3 kg
12 and 20 W: approx. 0.5 kg

For CAD models on individual code numbers, visit www.danfoss.com/products/categories/

Dimensions and weights

EVR 4 - EVR 6 - EVR 8
Solder connection

Cable coil ¹⁾

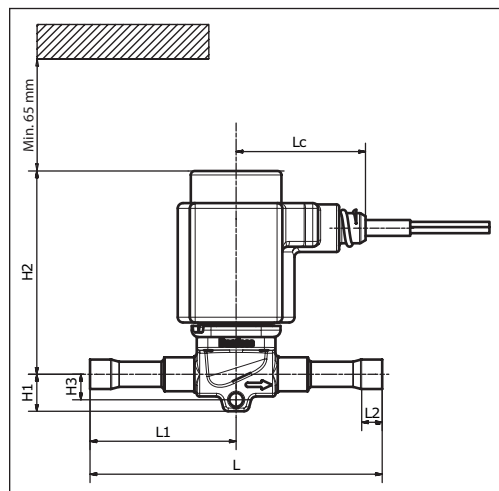

DIN plug coil ²⁾

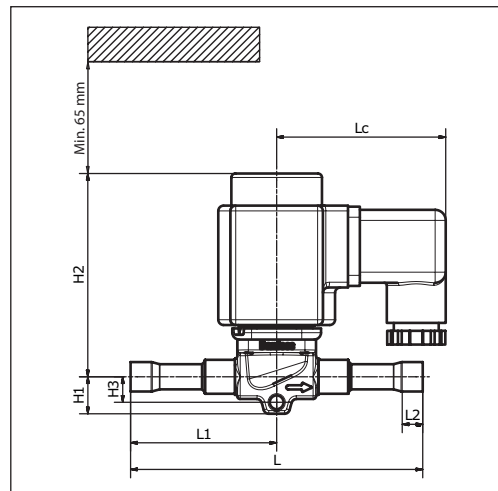

Terminal box coil ³⁾

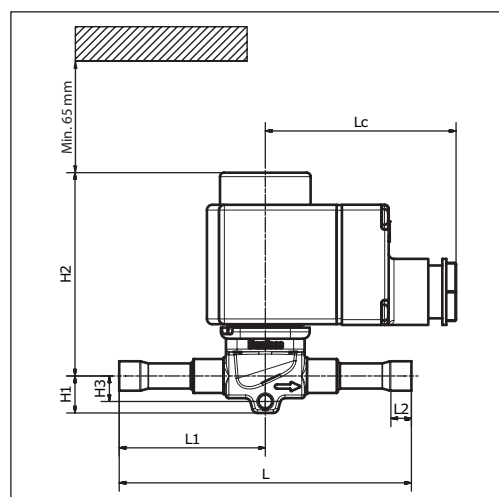

Manual stem

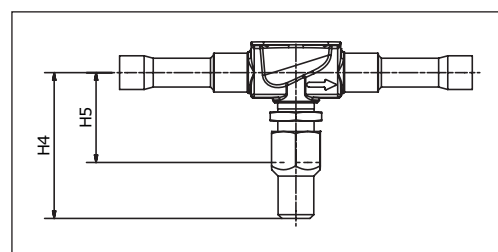

End view

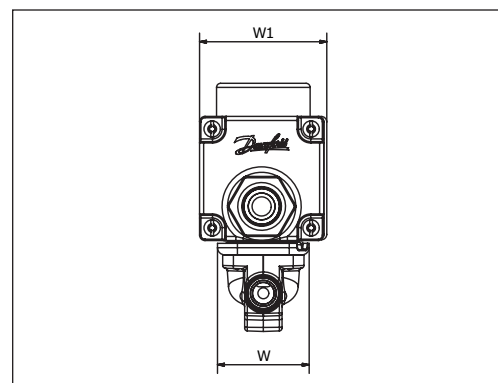

Type	Connection		Manual operation	H ₁	H ₂	H ₃	H ₄	H ₅	L	L ₁	L ₂	L _c	W	W ₁ max.	Net weight without coil [kg]
	[in]	[mm]		[mm]	[mm]	[mm]	[mm]	[mm]	[mm]	[mm]	[mm]	[mm]	[mm]	[mm]	
EVR 4	3/8	10	No	14	78	10	—	—	117	58.5	8	—	34	—	0.19
EVR 6	3/8	10	Yes	14	78	10	48	30	117	58.5	8	—	34	—	0.19
	3/8	10	No	14	78	10	—	—	111	55.5	8	—	34	—	0.19
	1/2	12	Yes	14	78	10	48	30	127	63.5	10	—	34	—	0.20
	1/2	12	No	14	78	10	—	—	127	63.5	10	—	34	—	0.20
EVR 8	1/2	12	Yes	14	78	10	48	30	127	63.5	10	—	34	—	0.20
	1/2	12	No	14	78	10	—	—	127	63.5	10	—	34	—	0.20
	5/8	16	No	14	78	10	—	—	163	81.5	12	—	34	—	0.20
Cable coil ¹⁾												49	—	46	—
DIN plug coil ²⁾												64	—	47	—
Terminal box coil 10 W ³⁾												72	—	47	—
Terminal box coil 12 / 20 W ³⁾												80	—	68	—

Net weight of coil
10 W: approx. 0.3 kg
12 and 20 W: approx. 0.5 kg

For 3D models, visit www.danfoss.com/products/categories/

Dimensions and weights

EVR 10
Solder connection

Cable coil ¹⁾

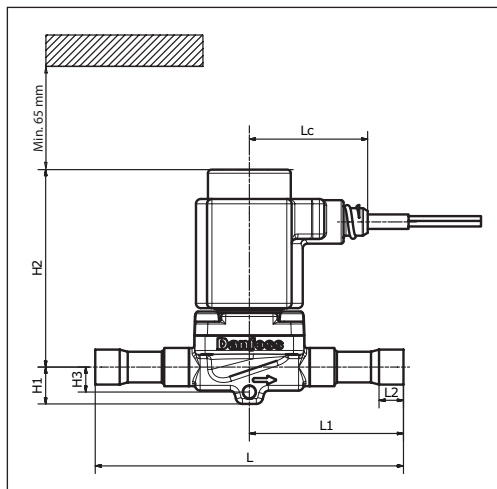

DIN plug coil ²⁾

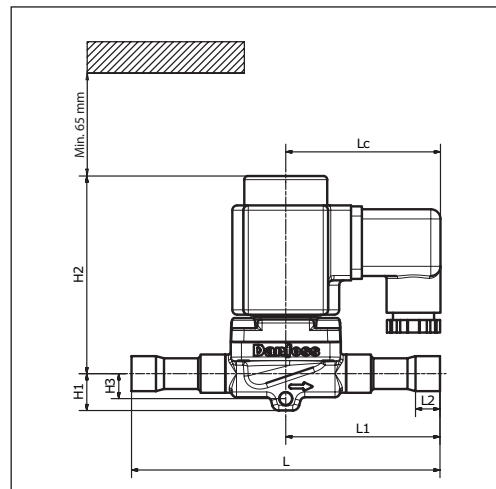

Terminal box coil ³⁾

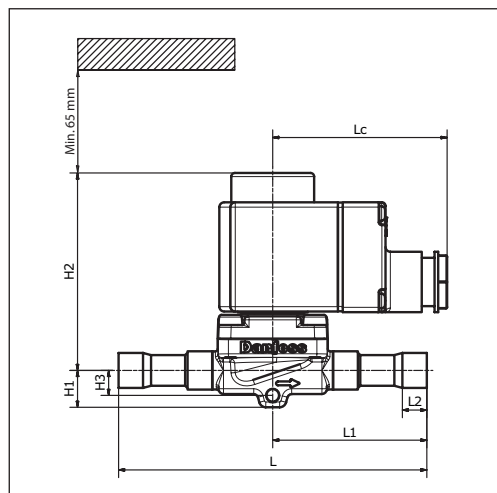

Manual stem

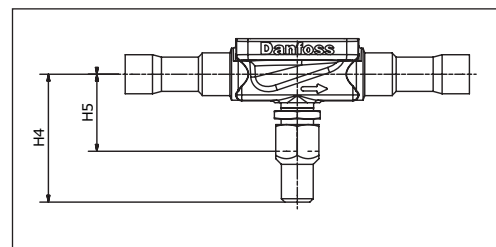

End view

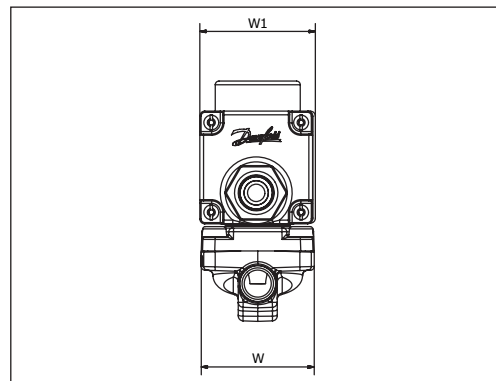

Type	Connection		Manual operation	H ₁ [mm]	H ₂ [mm]	H ₃ [mm]	H ₄ [mm]	H ₅ [mm]	L [mm]	L ₁ [mm]	L ₂ [mm]	L _c [mm]	W [mm]	W ₁ max. [mm]	Net weight without coil [kg]
	[in]	[mm]													
EVR 10	1/2	12	Yes	15	82	10	48	29	128	64	10	-	46	-	0.39
	3/8	10	No	15	82	10	-	-	118	59	-	-	46	-	0.34
	5/8	16	No	15	82	10	-	-	163	81.5	12	-	46	-	0.38
	5/8	16	Yes	15	82	10	48	29	163	81.5	12	-	46	-	0.40
Cable coil ¹⁾												49	-	46	-
DIN plug coil ²⁾												64	-	47	-
Terminal box coil 10 W ³⁾												72	-	47	-
Terminal box coil 12 / 20 W ³⁾												80	-	68	-

Net weight of coil
10 W: approx. 0.3 kg
12 and 20 W: approx. 0.5 kg

For 3D models, visit www.danfoss.com/products/categories/

Dimensions and weights

EVR 15 - EVR 18
Solder connection

Cable coil ¹⁾

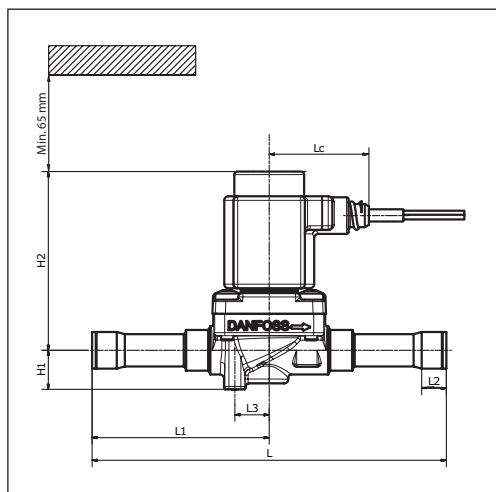

DIN plug coil ²⁾

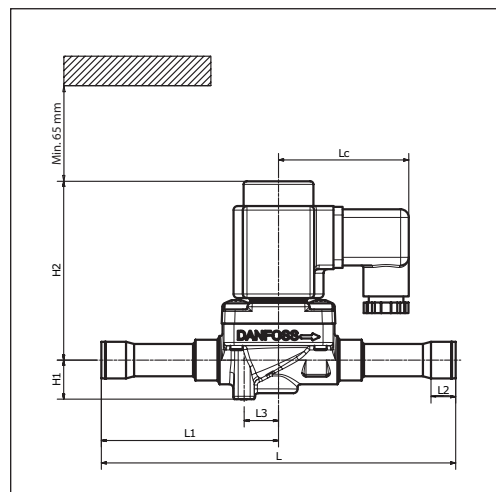

Terminal box coil ³⁾

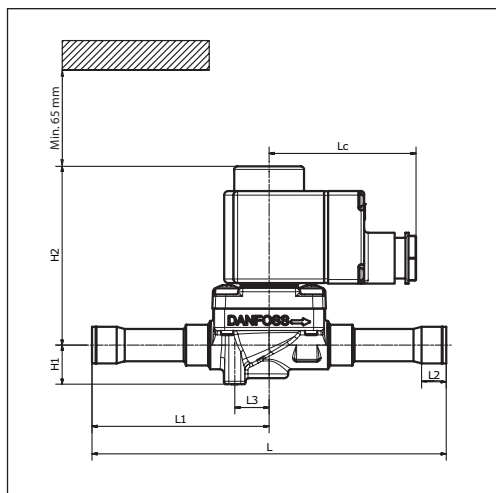

Manual stem

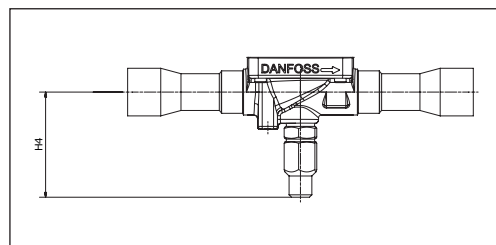

End view

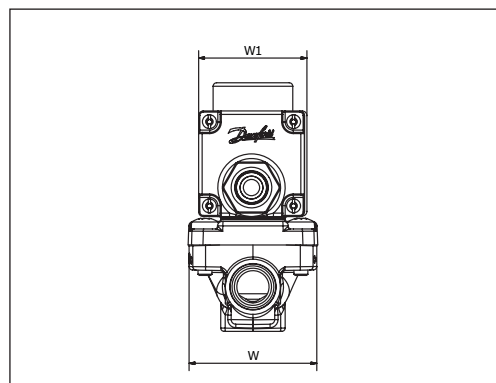

Type	Connection		Manual operation	H ₁ [mm]	H ₂ [mm]	H ₄ [mm]	L [mm]	L ₁ [mm]	L ₂ [mm]	L ₃ [mm]	L _c [mm]	W [mm]	W ₁ max. [mm]	Net weight without coil [kg]
	[in]	[mm]												
EVR 15	5/8	16	Yes	19	89	54	174	87	12	17	-	56	-	0.70
	5/8	16	No	19	89	-	174	87	12	17	-	56	-	0.70
	7/8	22	No	19	89	-	174	87	17	17	-	56	-	0.70
EVR 18	7/8	22	Yes	19	89	54	179	89.5	17	17	-	56	-	0.70
Cable coil ¹⁾											49	-	46	-
DIN plug coil ²⁾											64	-	47	-
Terminal box coil 10 W ³⁾											72	-	47	-
Terminal box coil 12 / 20 W ³⁾											80	-	68	-

Net weight of coil
10 W: approx. 0.3 kg
12 and 20 W: approx. 0.5 kg

For 3D models, visit www.danfoss.com/products/categories/

Dimensions and weights

EVR 20 - EVR 22
Solder connection

Cable coil ¹⁾

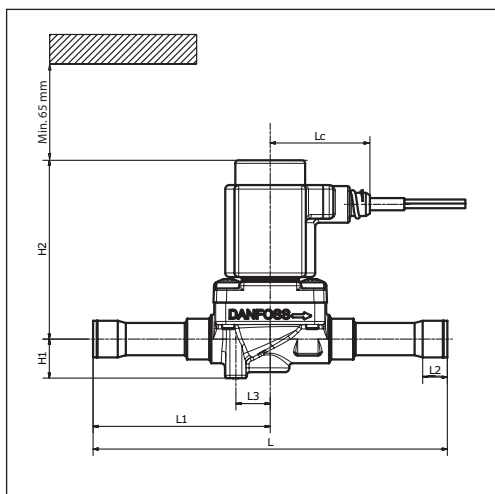

DIN plug coil ²⁾

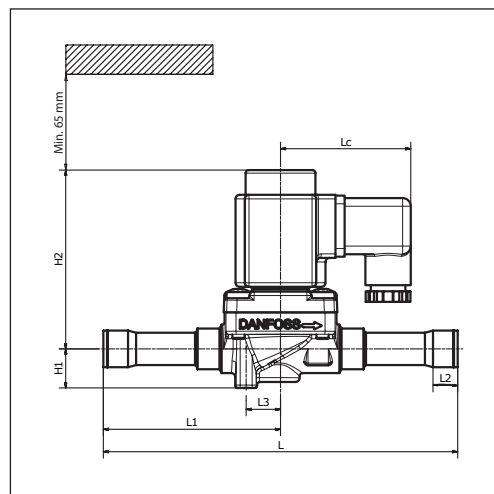

Terminal box coil ³⁾

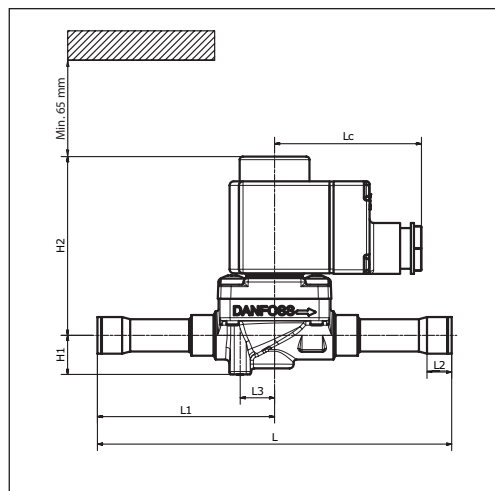

Manual stem

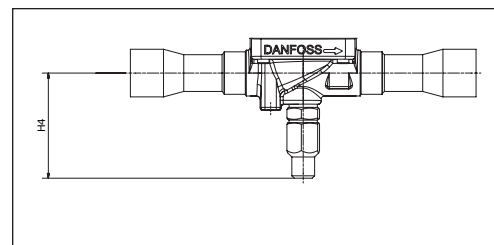

End view

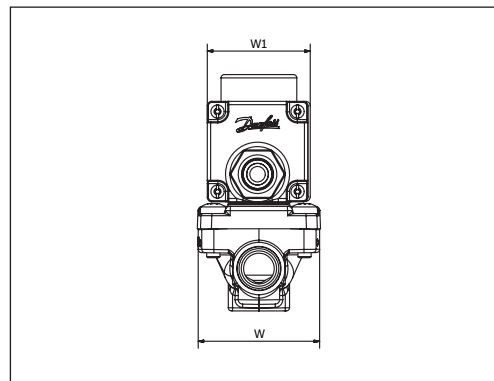

Type	Connection		Manual operation	H ₁ [mm]	H ₂ [mm]	H ₄ [mm]	L [mm]	L ₁ [mm]	L ₂ [mm]	L ₃ [mm]	L _c [mm]	W [mm]	W ₁ max. [mm]	Net weight without coil [kg]
	[in]	[mm]												
EVR 20	7/8	22	Yes	19	93	56	190	95	17	20	-	72	-	1.26
	7/8	22	No	19	93	-	190	95	17	20	-	72	-	1.26
	1 1/8	28	No	19	93	-	217	108.5	20	20	-	72	-	1.31
EVR 22	1 1/8	28	Yes	19	93	56	222	111	20	20	-	72	-	1.31
	1 1/8	28	No	19	93	-	267	133.5	20	20	-	72	-	1.47
	1 3/8	35	No	19	93	-	292	146	25	20	-	72	-	1.47
Cable coil ¹⁾											49	-	46	-
DIN plug coil ²⁾											64	-	47	-
Terminal box coil 10 W ³⁾											72	-	47	-
Terminal box coil 12 / 20 W ³⁾											80	-	68	-

Net weight of coil
10 W: approx. 0.3 kg
12 and 20 W: approx. 0.5 kg

For 3D models, visit www.danfoss.com/products/categories/

Dimensions and weights

EVR 25
Solder connection

Cable coil ¹⁾

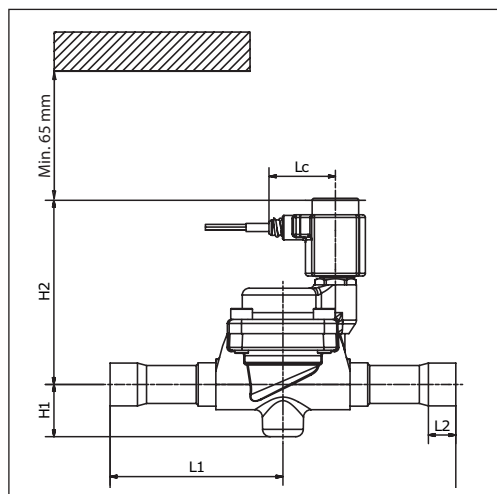

DIN plug coil ²⁾

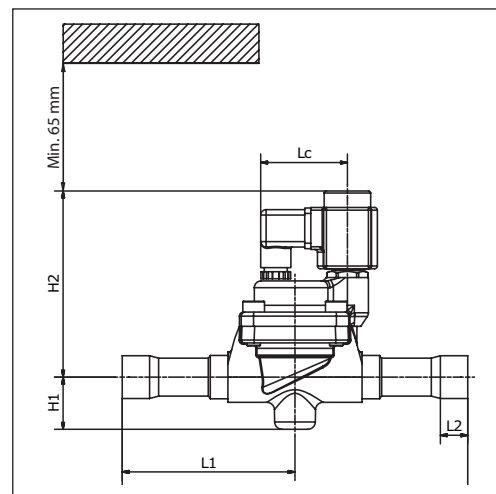

Terminal box coil ³⁾

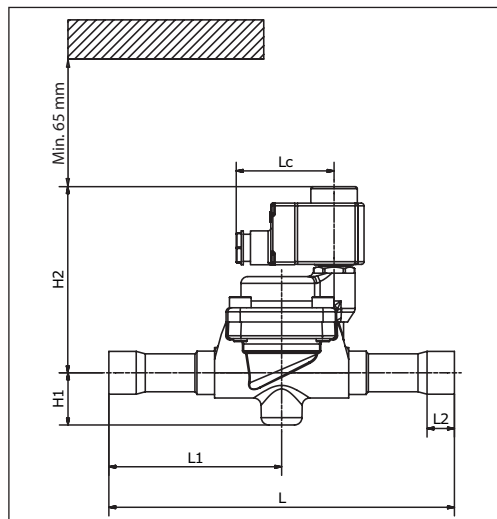

Manual stem

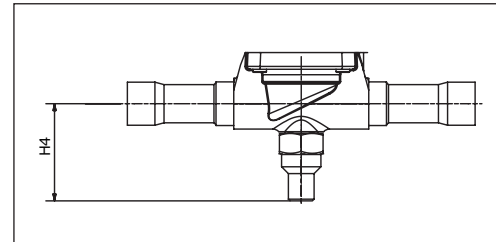

End view

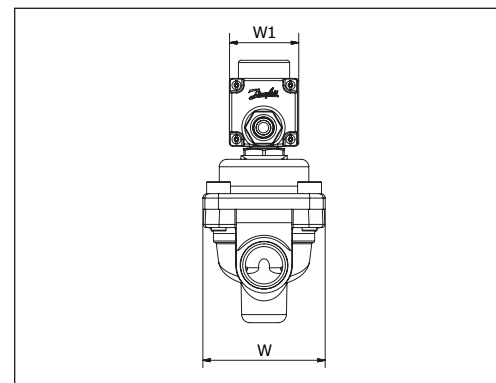

Type	Connection		Manual operation	H ₁ [mm]	H ₂ [mm]	H ₄ [mm]	L [mm]	L ₁ [mm]	L ₂ [mm]	L _c [mm]	W [mm]	W ₁ max. [mm]	Net weight without coil [kg]	
	[in]	[mm]												
EVR 25	1 1/8	28	Yes	39	138	71	255	127.5	20	-	82	-	2.67*	
	1 1/8	28	No	39	138	-	255	127.5	20	-	82	-	2.67*	
	1 3/8	35	Yes	39	138	71	281	140.5	25	-	82	-	2.80*	
	1 3/8	35	No	39	138	-	281	140.5	25	-	82	-	2.80*	
* Manual stem: +0.060 kg														
Cable coil ¹⁾											49	-	46	-
DIN plug coil ²⁾											64	-	47	-
Terminal box coil 10 W ³⁾											72	-	47	-
Terminal box coil 12 / 20 W ³⁾											80	-	68	-

Net weight of coil
10 W: approx. 0.3 kg
12 and 20 W: approx. 0.5 kg

For 3D models, visit www.danfoss.com/products/categories/

Dimensions and weights

EVR 32 - EVR 40
Solder connection

Cable coil ¹⁾

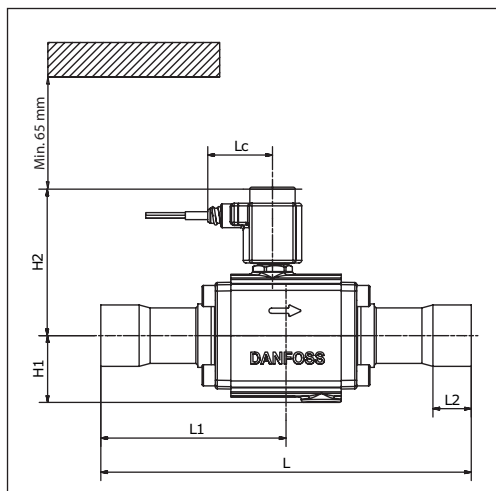

DIN plug coil ²⁾

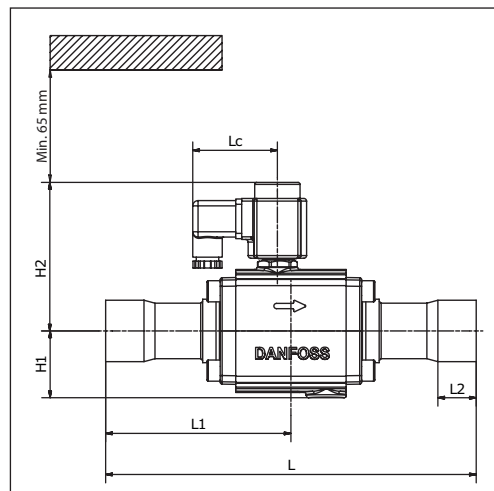

Terminal box coil ³⁾

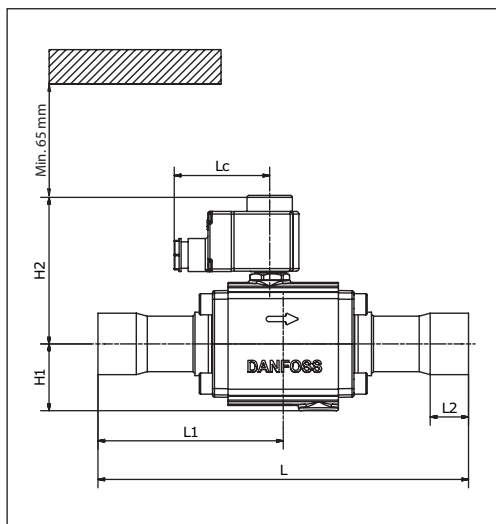

Manual stem

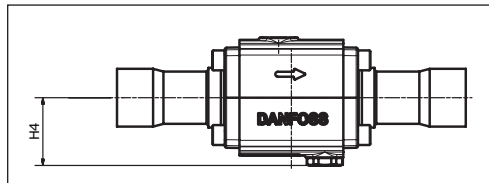

End view

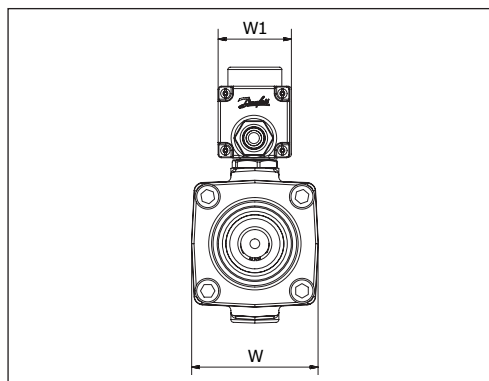

Type	Connection		Manual operation	H ₁ [mm]	H ₂ [mm]	H ₄ [mm]	L [mm]	L ₁ [mm]	L ₂ [mm]	L _c [mm]	W [mm]	W ₁ max. [mm]	Net weight without coil [kg]
	[in]	[mm]											
EVR 32	1 3/8	35	Yes	-	111	55	280	140	25	-	81	-	4.30
	1 3/8	35	No	51	111	-	280	140	25	-	81	-	4.30
	1 5/8	42	Yes	-	111	55	280	140	29	-	81	-	4.40
	1 5/8	42	No	51	111	-	280	140	29	-	81	-	4.40
	2 1/8	-	Yes	-	111	55	280	140	34	-	80	-	4.57
	2 1/8	-	No	51	111	-	280	140	34	-	80	-	4.57
EVR 40	1 5/8	42	Yes	-	111	55	280	140	29	-	81	-	4.40
	1 5/8	42	No	51	111	-	280	140	29	-	81	-	4.40
	2 1/8	-	Yes	-	111	55	280	140	34	-	80	-	4.57
	2 1/8	-	No	51	111	-	280	140	34	-	80	-	4.57
Cable coil ¹⁾										49	-	46	-
DIN plug coil ²⁾										64	-	47	-
Terminal box coil 10 W ³⁾										72	-	47	-
Terminal box coil 12 / 20 W ³⁾										80	-	68	-

Net weight of coil
10 W: approx. 0.3 kg
12 and 20 W: approx. 0.5 kg

For 3D models, visit www.danfoss.com/products/categories/

Dimensions and weights

EVRC 15
Solder connection

Cable coil ¹⁾

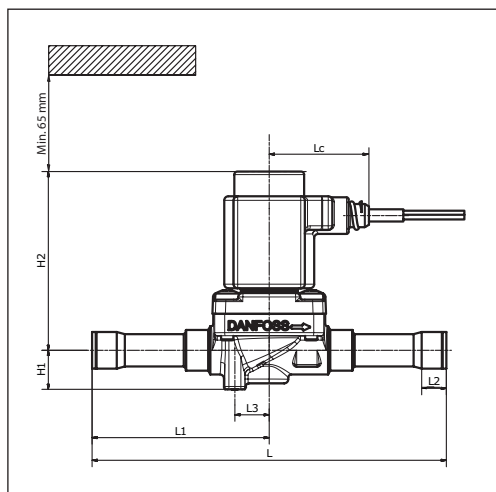

DIN plug coil ²⁾

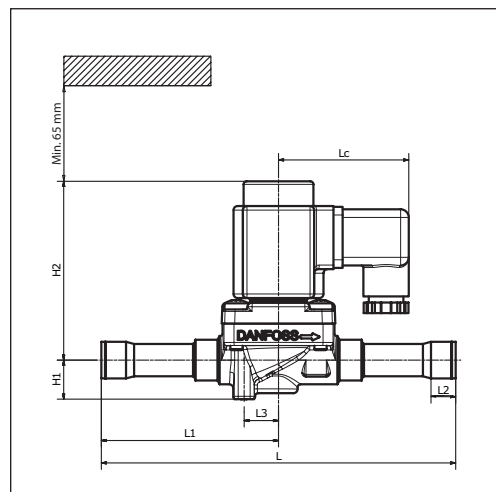

Terminal box coil ³⁾

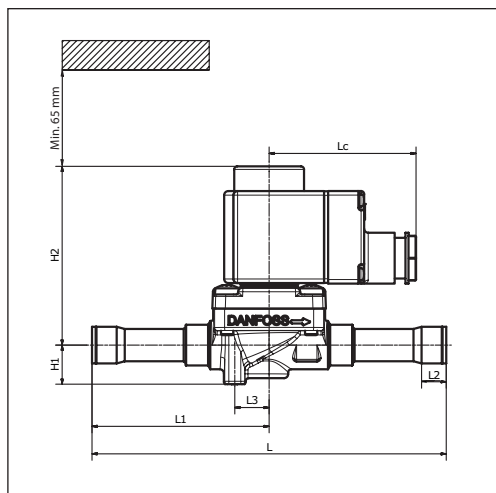

End view

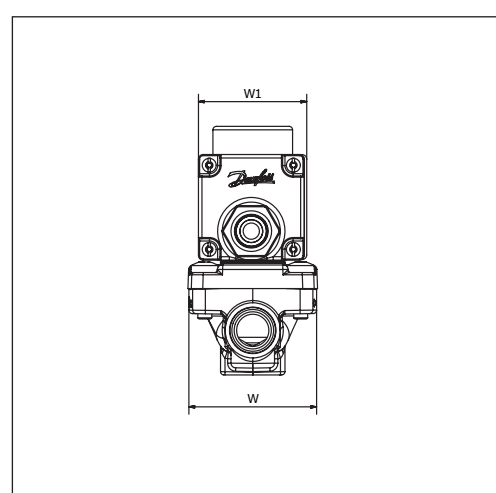

Type	Connection		Manual operation	H ₁ [mm]	H ₂ [mm]	L [mm]	L ₁ [mm]	L ₂ [mm]	L ₃ [mm]	L _c [mm]	W [mm]	W ₁ max. [mm]	Net weight without coil [kg]	
	[in]	[mm]												
EVRC 15	5/8	16	No	19	89	174	87	12	17	-	56	-	0.70	
Cable coil ¹⁾											49	-	46	-
DIN plug coil ²⁾											64	-	47	-
Terminal box coil 10 W ³⁾											72	-	47	-
Terminal box coil 12 / 20 W ³⁾											80	-	68	-

Net weight of coil
10 W: approx. 0.3 kg
12 and 20 W: approx. 0.5 kg

For 3D models, visit www.danfoss.com/products/categories/

Dimensions and weights

EVRC 20
Solder connection

Cable coil ¹⁾

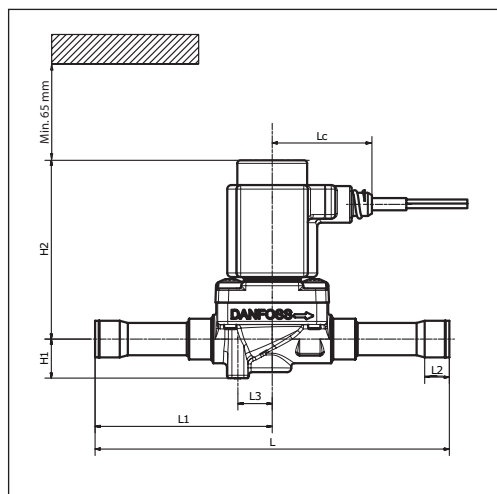

DIN plug coil ²⁾

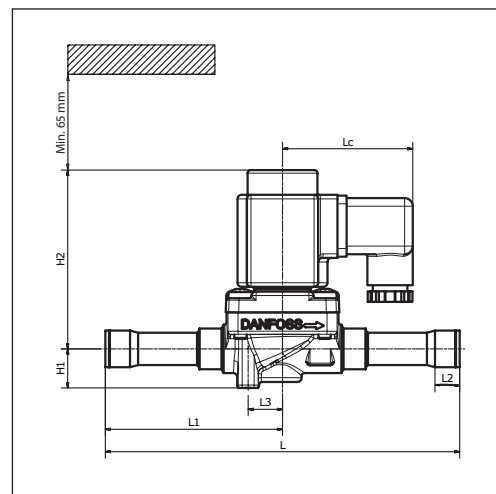

Terminal box coil ³⁾

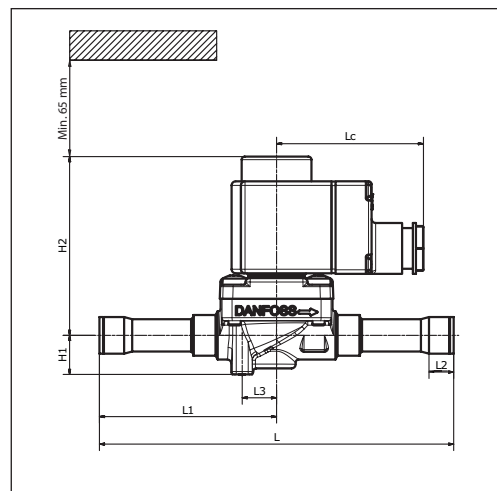

End view

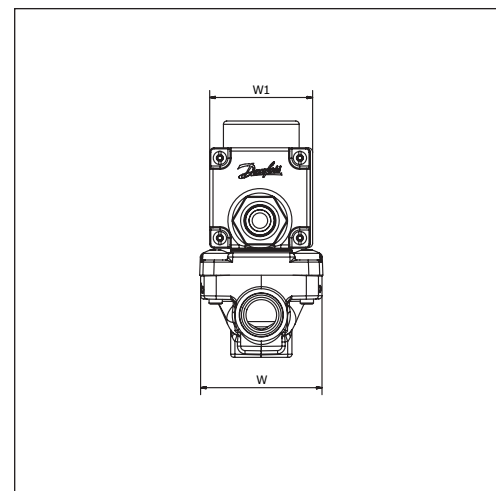

Type	Connection		Manual operation	H ₁ [mm]	H ₂ [mm]	L [mm]	L ₁ [mm]	L ₂ [mm]	L ₃ [mm]	L _c [mm]	W [mm]	W ₁ max. [mm]	Net weight without coil [kg]	
	[in]	[mm]												
EVRC 20	7/8	22	No	19	93	190	95	17	20	–	72	–	1.26	
Cable coil ¹⁾											49	–	46	–
DIN plug coil ²⁾											64	–	47	–
Terminal box coil 10 W ³⁾											72	–	47	–
Terminal box coil 12 / 20 W ³⁾											80	–	68	–

Net weight of coil
 10 W: approx. 0.3 kg
 12 and 20 W: approx. 0.5 kg

For 3D models, visit www.danfoss.com/products/categories/

Dimensions and weights

EVR 2 - EVR 3
Flare connection

Cable coil ¹⁾

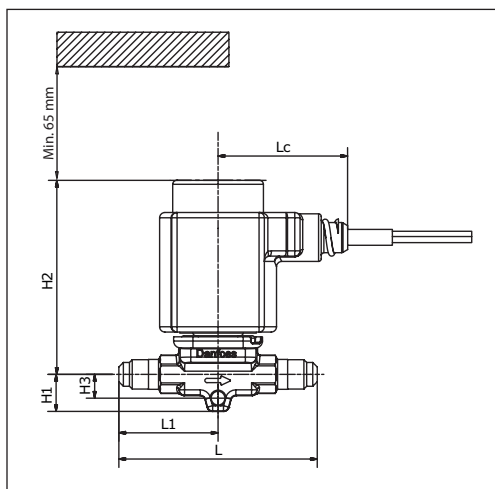

DIN plug coil ²⁾

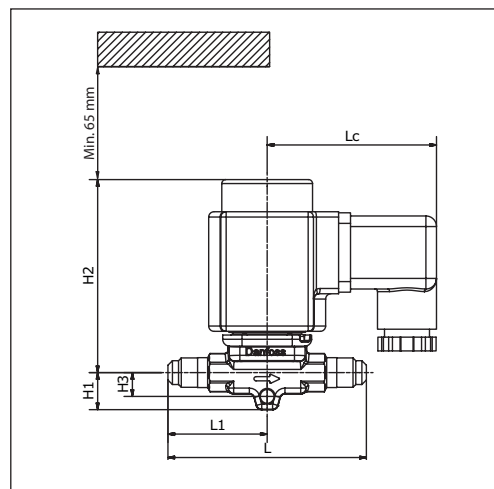

Terminal box coil ³⁾

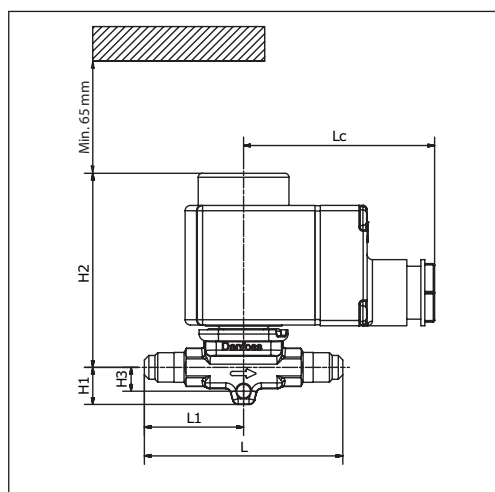

End view

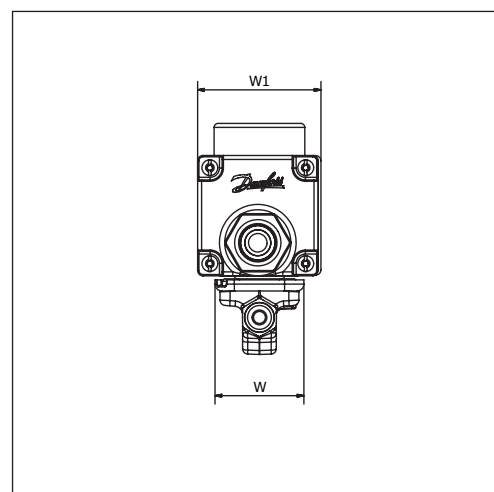

Type	Connection		H ₁ [mm]	H ₂ [mm]	H ₃ [mm]	L [mm]	L ₁ [mm]	L _c [mm]	W [mm]	W ₁ max. [mm]	Net weight without coil [kg]	
	[in]	[mm]										
EVR 2	1/4	6	14	73	9	75	37.5	–	34	–	0.18	
EVR 3	1/4	6	14	73	9	75	37.5	–	34	–	0.18	
	3/8	10	14	73	9	75	37.5	–	34	–	0.18	
Cable coil ¹⁾									49	–	46	–
DIN plug coil ²⁾									64	–	47	–
Terminal box coil 10 W ³⁾									72	–	47	–
Terminal box coil 12 / 20 W ³⁾									80		68	

Net weight of coil
10 W: approx. 0.3 kg
12 and 20 W: approx. 0.5 kg

For 3D models, visit www.danfoss.com/products/categories/

Dimensions and weights

EVR 6
Flare connection

Cable coil ¹⁾

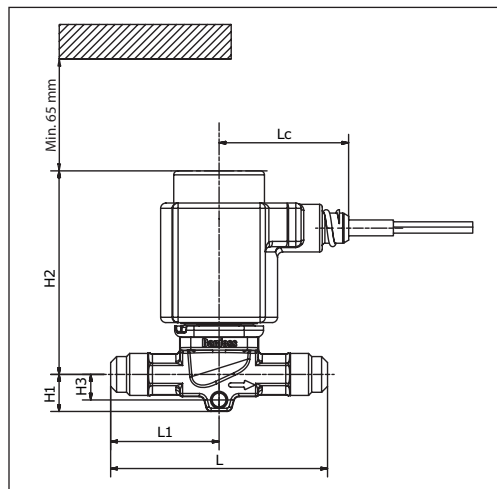

DIN plug coil ²⁾

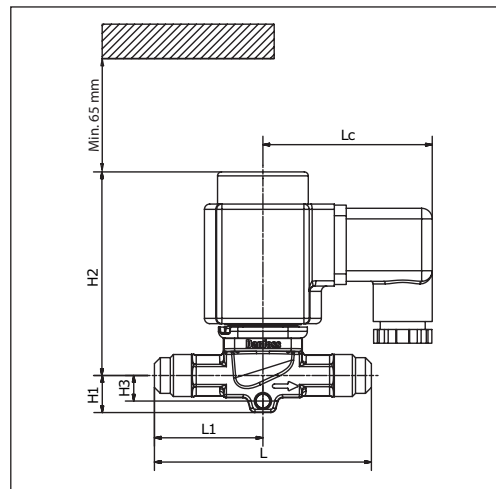

Terminal box coil ³⁾

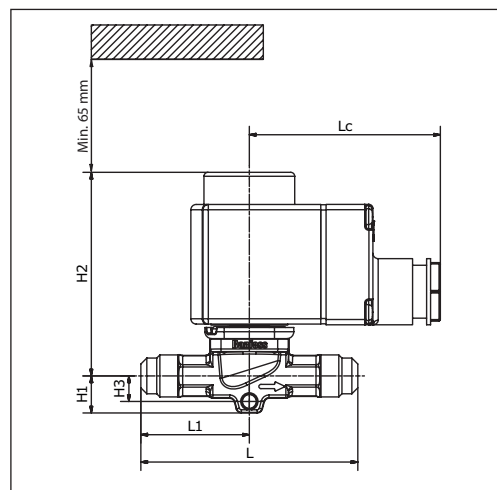

End view

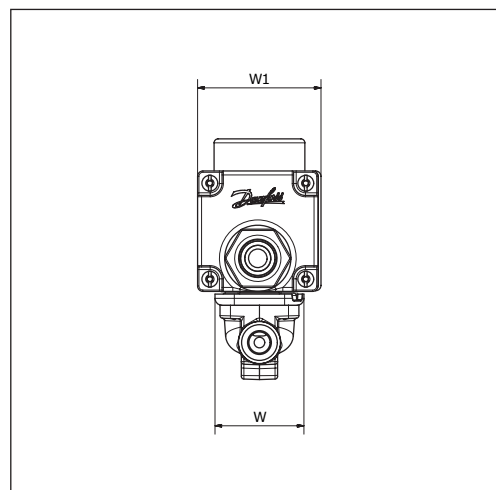

Type	Connection		H ₁ [mm]	H ₂ [mm]	H ₃ [mm]	L [mm]	L ₁ [mm]	L _c [mm]	W [mm]	W ₁ max. [mm]	Net weight without coil [kg]	
	[in]	[mm]										
EVR 6	3/8	10	14	77	10	82	41	–	34	–	0.21	
	1/2	12	14	77	10	88	44	–	34	–	0.22	
Cable coil ¹⁾									49	–	46	–
DIN plug coil ²⁾									64	–	47	–
Terminal box coil 10 W ³⁾									72	–	47	–
Terminal box coil 12 / 20 W ³⁾									80	–	68	–

Net weight of coil
10 W: approx. 0.3 kg
12 and 20 W: approx. 0.5 kg

For 3D models, visit www.danfoss.com/products/categories/

Dimensions and weights

EVR 10
Flare connection

Cable coil ¹⁾

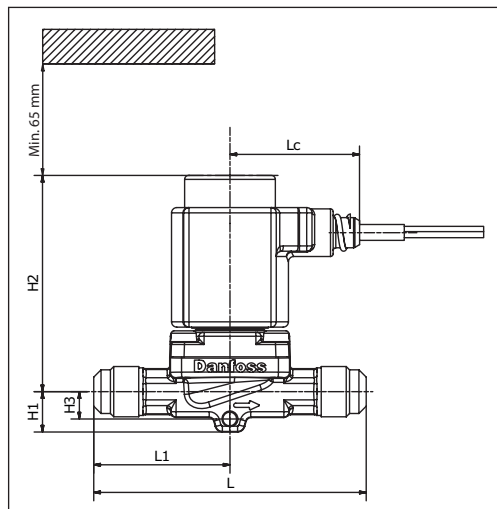

DIN plug coil ²⁾

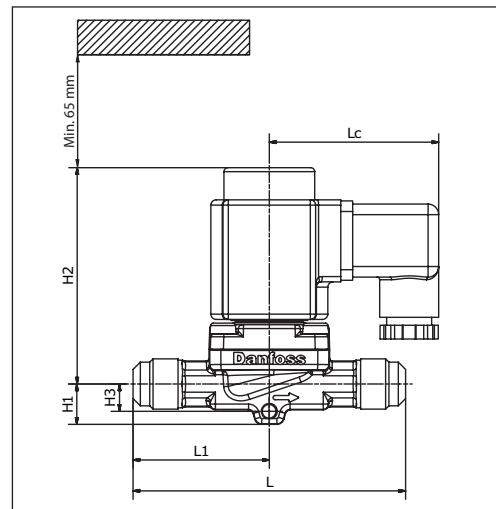

Terminal box coil ³⁾

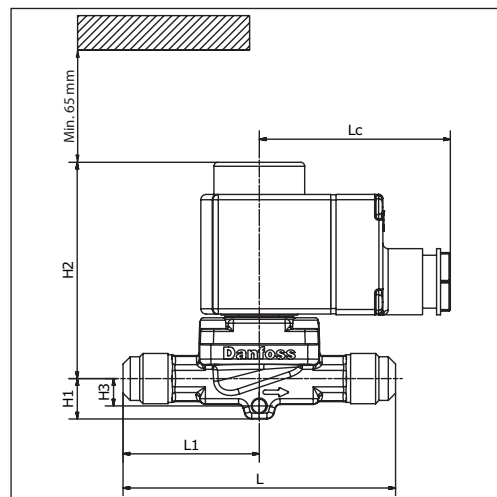

End view

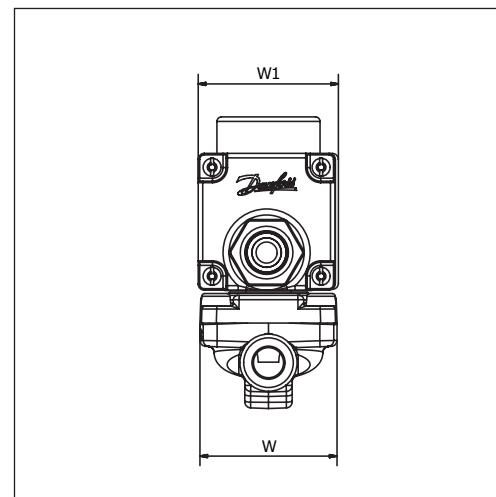

Type	Connection		H ₁ [mm]	H ₂ [mm]	H ₃ [mm]	L [mm]	L ₁ [mm]	L _c [mm]	W [mm]	W ₁ max. [mm]	Net weight without coil [kg]	
	[in]	[mm]										
EVR 10	1/2	12	15	82	10	103	51.5	–	46	–	0.44	
	3/8	16	15	82	10	110	55	–	46	–	0.45	
Cable coil ¹⁾									49	–	46	–
DIN plug coil ²⁾									64	–	47	–
Terminal box coil 10 W ³⁾									72	–	47	–
Terminal box coil 12 / 20 W ³⁾									80	–	68	–

Net weight of coil
 10 W: approx. 0.3 kg
 12 and 20 W: approx. 0.5 kg

For 3D models, visit www.danfoss.com/products/categories/

Dimensions and weights

EVR 15
Flare connection

Cable coil ¹⁾

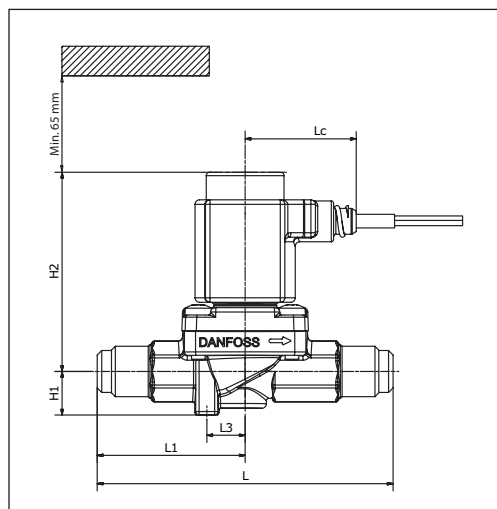

DIN plug coil ²⁾

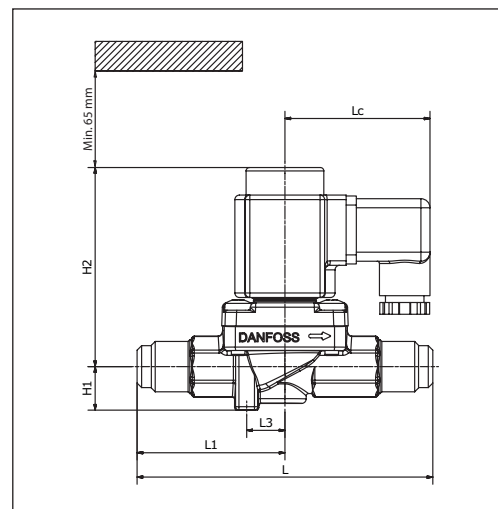

Terminal box coil ³⁾

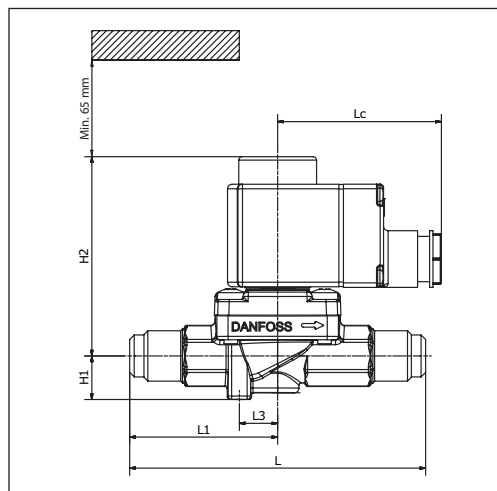

Manual stem

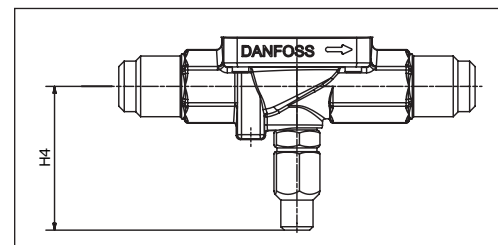

End view

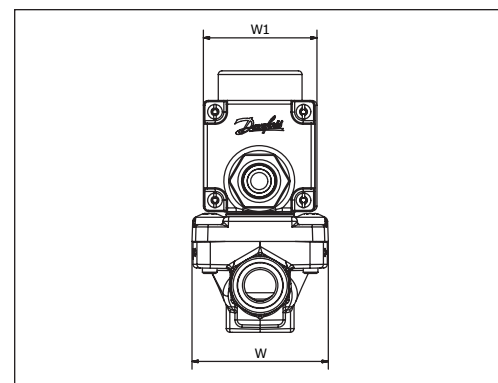

Type	Connection		Manual operation	H ₁ [mm]	H ₂ [mm]	H ₄ [mm]	L [mm]	L ₁ [mm]	L ₃ [mm]	L _c [mm]	W [mm]	W, max. [mm]	Net weight without coil [kg]
	[in]	[mm]											
EVR 15	5/8	16	Yes	19	89	53	131	65.5	17	-	56	-	0.78
	5/8	16	No	19	89	-	131	65.5	17	-	56	-	0.78
Cable coil ¹⁾										49	-	46	-
DIN plug coil ²⁾										64	-	47	-
Terminal box coil 10 W ³⁾										72	-	47	-
Terminal box coil 12 / 20 W ³⁾										80	-	68	-

Net weight of coil
10 W: approx. 0.3 kg
12 and 20 W: approx. 0.5 kg

For 3D models, visit www.danfoss.com/products/categories/

Dimensions and weights

EVR 15
Flange connection

Cable coil ¹⁾

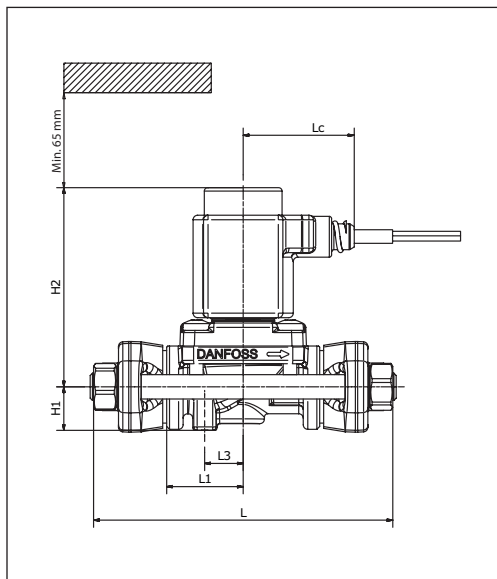

DIN plug coil ²⁾

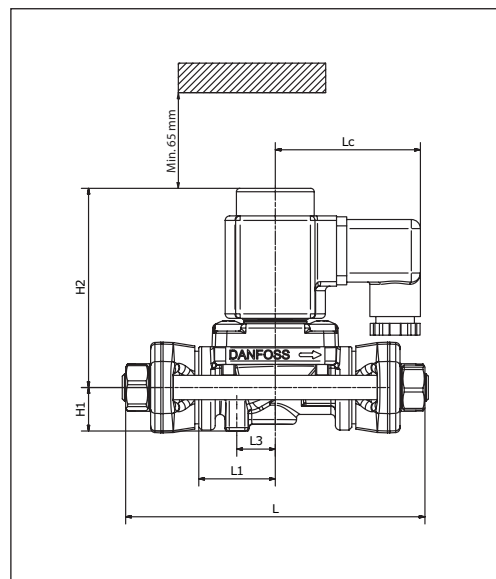

Terminal box coil ³⁾

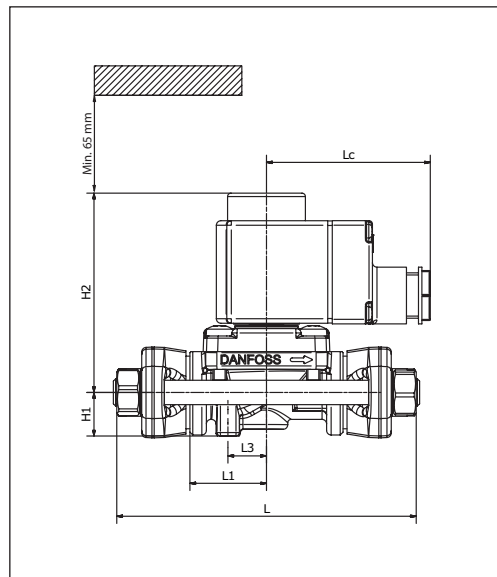

Manual stem

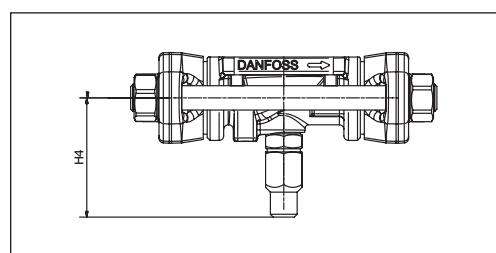

End view

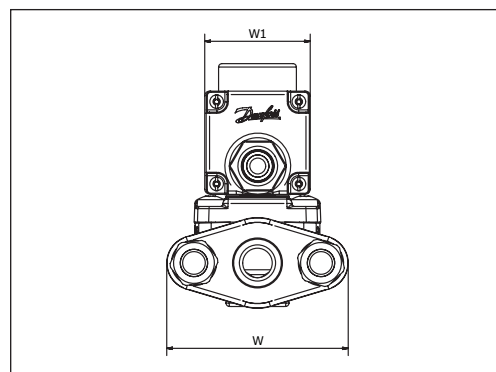

Type	Manual operation	H ₁ [mm]	H ₂ [mm]	H ₄ [mm]	L [mm]	L ₁ [mm]	L ₃ [mm]	L _c [mm]	W [mm]	W ₁ max. [mm]	Net weight without coil [kg]
EVR 15	Yes	19	89	53	126	33.8	17	–	80	–	0.64
	No	19	89	–	126	33.8	17	–	80	–	0.64
Cable coil ¹⁾								49	–	46	–
DIN plug coil ²⁾								64	–	47	–
Terminal box coil 10 W ³⁾								72	–	47	–
Terminal box coil 12 / 20 W ³⁾								80	–	68	–

Net weight of coil
 10 W: approx. 0.3 kg
 12 and 20 W: approx. 0.5 kg
 Weight of flange set
 0.6 kg

For 3D models, visit www.danfoss.com/products/categories/

Dimensions and weights

EVR 20
Flange connection

Cable coil ¹⁾

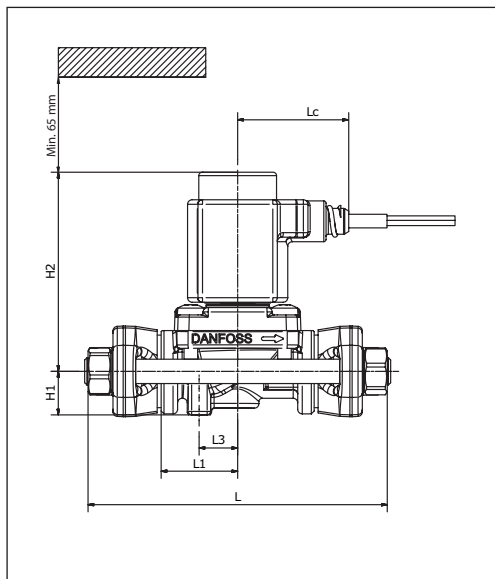

DIN plug coil ²⁾

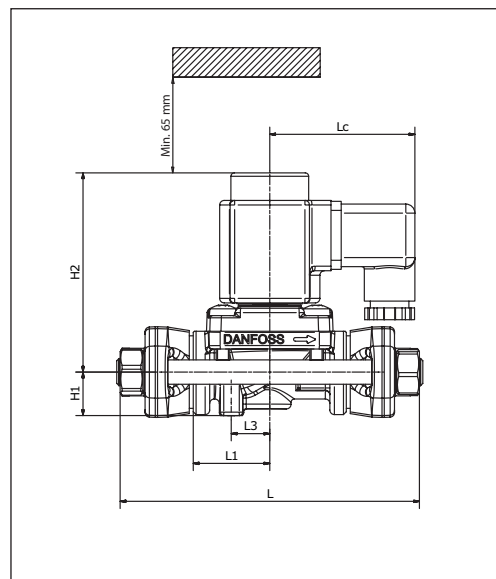

Terminal box coil ³⁾

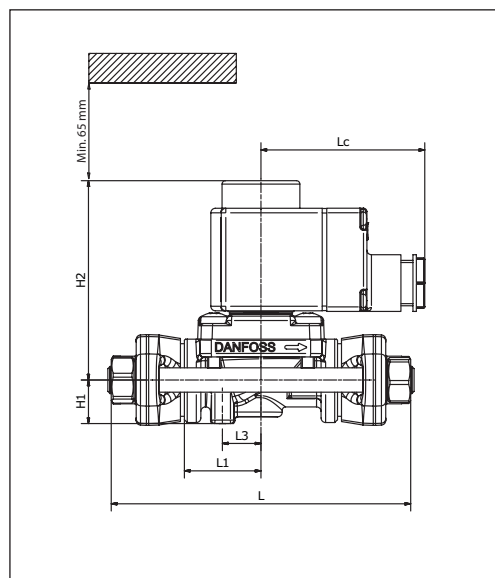

Manual stem

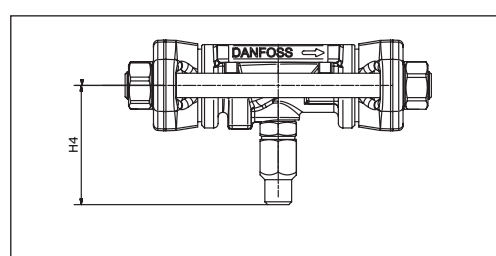

End view

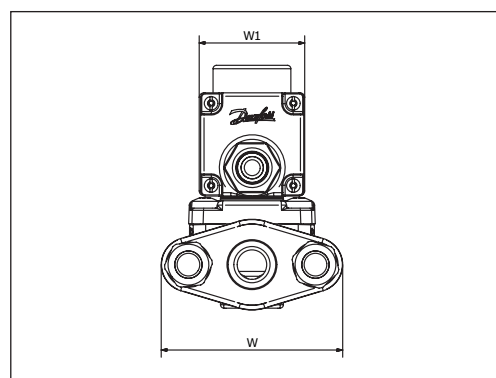

Type	Manual operation	H ₁ [mm]	H ₂ [mm]	H ₄ [mm]	L [mm]	L ₁ [mm]	L ₃ [mm]	L _c [mm]	W [mm]	W ₁ max. [mm]	Net weight without coil [kg]
EVR 20	Yes	19	93	56	156	42.5	20	–	96	–	1.20
	No	19	93	–	156	42.5	20	–	96	–	1.20
Cable coil ¹⁾								49	–	46	–
DIN plug coil ²⁾								64	–	47	–
Terminal box coil 10 W ³⁾								72	–	47	–
Terminal box coil 12 / 20 W ³⁾								80	–	68	–

Net weight of coil
 10 W: approx. 0.3 kg
 12 and 20 W: approx. 0.5 kg
 Weight of flange set
 0.9 kg

For 3D models, visit www.danfoss.com/products/categories/

**Extended capacity
Liquid**

Type	Liquid capacity Q_e [kW] at pressure drop across valve Δp [bar]				
	0.1	0.2	0.3	0.4	0.5
R22/R407C					
EVR 2	2.46	3.48	4.27	4.93	5.51
EVR 3	4.43	6.27	7.68	8.87	9.92
EVR 4	11.17	15.79	19.34	22.34	24.97
EVR 6	14.62	20.67	25.32	29.24	32.69
EVR 8	17.41	24.62	30.15	34.82	38.93
EVR 10	30.71	43.44	53.20	61.43	68.68
EVR 15	47.30	66.90	81.93	94.60	105.77
EVR 18	61.92	87.57	107.25	123.84	138.46
EVR 20	98.22	138.90	170.12	196.44	219.62
EVR 22	112.01	158.41	194.02	224.03	250.47
EVR 25	51.75	227.40	278.51	321.59	359.55
EVR 32	88.41	388.60	475.94	549.56	614.43
EVR 40	127.81	562.11	688.44	794.94	888.78
R134a					
EVR 2	2.28	3.22	3.95	4.56	5.10
EVR 3	4.10	5.80	7.11	8.21	9.17
EVR 4	10.33	14.61	17.90	20.67	23.10
EVR 6	13.52	19.13	23.42	27.05	30.24
EVR 8	16.11	22.78	27.90	32.21	36.02
EVR 10	28.42	40.19	49.22	56.83	63.54
EVR 15	43.76	61.89	75.80	87.52	97.86
EVR 18	57.29	81.01	99.22	114.57	128.10
EVR 20	90.87	128.51	157.39	181.74	203.19
EVR 22	103.63	146.56	179.50	207.26	231.73
EVR 25	47.87	210.38	257.66	297.52	332.64
EVR 32	81.79	359.52	440.32	508.43	568.45
EVR 40	118.24	520.04	636.92	735.45	822.26

Capacities are based on:
 – liquid temperature $t_l = 25\text{ °C}$ ahead of valve,
 – evaporating temperature $t_e = -10\text{ °C}$, superheat 0 K.

Correction factors

When sizing valves, the plant capacity must be multiplied by a correction factor depending on liquid temperature t_l ahead of valve/evaporator.

When the corrected capacity is known, the selection can be made from the table.

Correction factors based on liquid temperature t_l

t_l [°C]	-10	0	10	15	20	25	30	35	40	45	50
R22	1.31	1.22	1.13	1.09	1.04	1.00	0.96	0.91	0.86	0.82	0.77
R407C	1.38	1.27	1.16	1.11	1.05	1.00	0.94	0.89	0.83	0.77	0.72
R134a	1.37	1.27	1.16	1.11	1.05	1.00	0.95	0.89	0.84	0.78	0.73

**Extended capacity
Liquid**
(continued)

Type	Liquid capacity Q_e [kW] at pressure drop across valve Δp [bar]				
	0.1	0.2	0.3	0.4	0.5
R404A/R507					
EVR 2	1.67	2.36	2.89	3.34	3.73
EVR 3	3.00	4.25	5.20	6.01	6.72
EVR 4	7.56	10.70	13.10	15.13	16.91
EVR 6	9.90	14.00	17.15	19.80	22.13
EVR 8	11.79	16.67	20.42	23.58	26.36
EVR 10	20.80	29.41	36.02	41.60	46.51
EVR 15	32.03	45.30	55.48	64.07	71.63
EVR 18	41.93	59.30	72.63	83.86	93.76
EVR 20	66.51	94.06	115.20	133.02	148.73
EVR 22	75.85	107.28	131.38	151.71	169.62
EVR 25	35.04	153.99	188.60	217.78	243.48
EVR 32	59.87	263.15	322.30	372.16	416.08
EVR 40	86.55	380.65	466.20	538.33	601.87
R410A					
EVR 2	2.42	3.42	4.18	4.83	5.40
EVR 3	4.35	6.15	7.53	8.69	9.72
EVR 4	10.95	15.48	18.96	21.90	24.48
EVR 6	14.33	20.27	24.82	28.66	32.04
EVR 8	17.07	24.14	29.56	34.14	38.16
EVR 10	30.11	42.58	52.15	60.22	67.33
EVR 15	46.37	65.58	80.32	92.74	103.69
EVR 18	60.70	85.85	105.14	121.41	135.73
EVR 20	96.29	136.17	166.77	192.57	215.30
EVR 22	109.81	155.30	190.20	219.62	245.55
EVR 25	50.73	222.93	273.03	315.27	352.48
EVR 32	86.67	380.96	466.58	538.76	602.35
EVR 40	125.29	551.06	674.90	779.31	871.30

Capacities are based on:
 – liquid temperature
 $t_i = 25\text{ °C}$ ahead of valve,
 – evaporating temperature
 $t_e = -10\text{ °C}$, superheat 0 K.

Correction factors

When sizing valves, the plant capacity must be multiplied by a correction factor depending on liquid temperature t_i ahead of valve/evaporator.

When the corrected capacity is known, the selection can be made from the table.

Correction factors based on liquid temperature t_i

t_i [°C]	-10	0	10	15	20	25	30	35	40	45	50
R404A/R507	1.50	1.36	1.22	1.14	1.07	1.00	0.93	0.85	0.78	0.70	0.62
R410A	1.39	1.28	1.17	1.12	1.06	1.00	0.94	0.88	0.82	0.76	0.69

**Extended capacity
Liquid**
(continued)

Type	Liquid capacity Q_e [kW] at pressure drop across valve Δp [bar]				
	0.1	0.2	0.3	0.4	0.5
R32					
EVR 2	3.45	4.88	5.98	6.90	7.72
EVR 3	6.21	8.79	10.76	12.43	13.89
EVR 4	15.65	22.13	27.11	31.30	34.99
EVR 6	20.48	28.97	35.48	40.97	45.80
EVR 8	24.40	34.50	42.25	48.79	54.55
EVR 10	43.04	60.86	74.54	86.07	96.23
EVR 15	66.28	93.74	114.80	132.56	148.21
EVR 18	86.76	122.70	150.28	173.53	194.01
EVR 20	137.63	194.63	238.37	275.25	307.74
EVR 22	156.96	221.97	271.86	313.91	350.97
R290					
EVR 2	2.74	3.88	4.75	5.49	6.13
EVR 3	4.94	6.98	8.55	9.87	11.04
EVR 4	12.43	17.58	21.54	24.87	27.80
EVR 6	16.27	23.01	28.19	32.55	36.39
EVR 8	19.38	27.41	33.57	38.76	43.34
EVR 10	34.19	48.36	59.22	68.38	76.46
EVR 15	52.66	74.47	91.21	105.32	117.75
EVR 18	68.93	97.49	119.40	137.87	154.14
EVR 20	109.34	154.63	189.39	218.68	244.50
EVR 22	124.70	176.35	215.99	249.40	278.84
R600a					
EVR 2	2.76	3.91	4.78	5.52	6.18
EVR 3	4.97	7.03	8.61	9.94	11.12
EVR 4	12.52	17.71	21.69	25.04	28.00
EVR 6	16.39	23.17	28.38	32.77	36.64
EVR 8	19.52	27.60	33.80	39.03	43.64
EVR 10	34.43	48.69	59.64	68.86	76.99
EVR 15	53.03	74.99	91.85	106.05	118.57
EVR 18	69.41	98.17	120.23	138.83	155.21
EVR 20	110.10	155.71	190.71	220.21	246.20
EVR 22	125.57	177.58	217.50	251.14	280.79

Capacities are based on:
 – liquid temperature
 $t_l = 25\text{ °C}$ ahead of valve,
 – evaporating temperature
 $t_e = -10\text{ °C}$, superheat 0 K.

Correction factors

When sizing valves, the plant capacity must be multiplied by a correction factor depending on liquid temperature t_l ahead of valve/evaporator.

When the corrected capacity is known, the selection can be made from the table.

Correction factors based on liquid temperature t_l

t_l [°C]	-10	0	10	15	20	25	30	35	40	45	50
R32	1.31	1.23	1.14	1.09	1.05	1.00	0.95	0.90	0.86	0.81	0.75
R290	1.36	1.26	1.16	1.11	1.05	1.00	0.95	0.89	0.84	0.78	0.73
R600a	1.34	1.25	1.15	1.10	1.05	1.00	0.95	0.90	0.85	0.80	0.75

Capacity Suction

Type	Pressure drop Δp [bar]	Suction vapour capacity Q_e [kW] at evaporating temperature t_e [°C]						
		-40	-30	-20	-10	0	10	15
R22/R407C								
EVR 2	0.1	0.14	0.18	0.22	0.27	0.33	0.40	0.43
	0.15	0.16	0.21	0.27	0.33	0.40	0.48	0.52
	0.2	0.18	0.24	0.31	0.38	0.46	0.55	0.60
EVR 3	0.1	0.25	0.32	0.40	0.49	0.60	0.71	0.77
	0.15	0.29	0.38	0.49	0.60	0.73	0.87	0.94
	0.2	0.33	0.43	0.55	0.69	0.83	1.00	1.09
EVR 4	0.1	0.62	0.80	1.01	1.24	1.50	1.79	1.95
	0.15	0.74	0.97	1.22	1.51	1.83	2.19	2.38
	0.2	0.82	1.09	1.39	1.73	2.10	2.51	2.74
EVR 6	0.1	0.81	1.05	1.32	1.63	1.97	2.35	2.55
	0.15	0.97	1.26	1.60	1.98	2.40	2.86	3.11
	0.2	1.08	1.43	1.82	2.26	2.75	3.29	3.58
EVR 8	0.1	0.97	1.25	1.58	1.94	2.35	2.80	3.04
	0.15	1.15	1.50	1.91	2.35	2.85	3.41	3.71
	0.2	1.29	1.70	2.17	2.69	3.28	3.92	4.27
EVR 10	0.1	1.71	2.21	2.78	3.42	4.14	4.93	5.36
	0.15	2.03	2.65	3.36	4.15	5.04	6.02	6.54
	0.2	2.27	3.01	3.83	4.75	5.78	6.91	7.52
EVR 15	0.1	2.63	3.40	4.28	5.27	6.37	7.60	8.26
	0.15	3.12	4.09	5.18	6.40	7.76	9.26	10.07
	0.2	3.49	4.63	5.90	7.32	8.90	10.65	11.59
EVR 18	0.1	3.44	4.45	5.60	6.90	8.34	9.95	10.81
	0.15	4.09	5.35	6.78	8.37	10.15	12.13	13.19
	0.2	4.57	6.06	7.72	9.58	11.65	13.94	15.17

Capacities are based on liquid temperature $t_l = 25$ °C ahead of evaporator.

The table values refer to the evaporator capacity and are given as a function of evaporating temperature t_e and pressure drop Δp across valve.

Capacities are based on dry, saturated vapour ahead of valve.

During operation with superheated vapour ahead of valve, the capacities are reduced by 4% for each 10 K superheat.

Correction factors

When sizing valves, the evaporator capacity must be multiplied by a correction factor depending on liquid temperature t_l ahead of expansion valve.

When the corrected capacity is known, the selection can be made from the table.

Correction factors for evaporating temperature t_e

t_l [°C]	-40	-30	-20	-10	0	10	15
R22	0.52	0.66	0.82	1.00	1.20	1.43	1.56
R407C	0.48	0.63	0.80	1.00	1.23	1.49	1.64

Extended capacity
Suction
(continued)

Capacities are based on liquid temperature $t_l = 25\text{ °C}$ ahead of evaporator.

The table values refer to the evaporator capacity and are given as a function of evaporating temperature t_e and pressure drop Δp across valve.

Capacities are based on dry, saturated vapour ahead of valve.

During operation with superheated vapour ahead of valve, the capacities are reduced by 4% for each 10 K superheat.

Type	Pressure drop Δp [bar]	Suction vapour capacity Q_e [kW] at evaporating temperature t_e [°C]						
		-40	-30	-20	-10	0	10	15
R22/R407C (continued)								
EVR 20	0.1	5.46	7.07	8.89	10.94	13.23	15.78	17.15
	0.15	6.49	8.49	10.75	13.28	16.11	19.24	20.92
	0.2	7.25	9.61	12.25	15.20	18.48	22.11	24.06
EVR 22	0.1	6.23	8.06	10.14	12.48	15.09	17.99	19.56
	0.15	7.40	9.68	12.26	15.15	18.37	21.94	23.86
	0.2	8.27	10.96	13.97	17.34	21.08	25.22	27.44
EVR 25	0.2	11.87	15.73	20.06	24.89	30.26	36.20	39.39
EVR 32	0.2	20.29	26.88	34.27	42.53	51.71	61.86	67.32
EVR 40	0.2	29.35	38.89	49.58	61.52	74.79	89.48	97.38

Correction factors

When sizing valves, the evaporator capacity must be multiplied by a correction factor depending on liquid temperature t_l ahead of expansion valve.

When the corrected capacity is known, the selection can be made from the table.

Correction factors for evaporating temperature t_e

t_l [°C]	-40	-30	-20	-10	0	10	15
R22	0.52	0.66	0.82	1.00	1.20	1.43	1.56
R407C	0.48	0.63	0.80	1.00	1.23	1.49	1.64

**Extended capacity
Suction**
(continued)

Type	Pressure drop Δp [bar]	Suction vapour capacity Q_e [kW] at evaporating temperature t_e [°C]						
		-40	-30	-20	-10	0	10	15
R134a								
EVR 2	0.1	0.08	0.12	0.16	0.20	0.25	0.31	0.35
	0.15	0.10	0.14	0.19	0.24	0.31	0.38	0.42
	0.2	0.10	0.15	0.21	0.28	0.35	0.43	0.48
EVR 3	0.1	0.15	0.21	0.28	0.36	0.46	0.56	0.62
	0.15	0.17	0.25	0.34	0.44	0.55	0.68	0.76
	0.2	0.18	0.27	0.38	0.50	0.63	0.78	0.87
EVR 4	0.1	0.38	0.53	0.71	0.91	1.15	1.42	1.56
	0.15	0.43	0.62	0.85	1.10	1.39	1.72	1.90
	0.2	0.46	0.69	0.95	1.25	1.59	1.97	2.18
EVR 6	0.1	0.50	0.70	0.93	1.19	1.50	1.85	2.05
	0.15	0.57	0.82	1.11	1.44	1.82	2.25	2.49
	0.2	0.60	0.90	1.24	1.63	2.08	2.58	2.86
EVR 8	0.1	0.59	0.83	1.10	1.42	1.79	2.21	2.44
	0.15	0.67	0.97	1.32	1.71	2.17	2.68	2.97
	0.2	0.72	1.08	1.48	1.94	2.47	3.07	3.40
EVR 10	0.1	1.05	1.46	1.95	2.51	3.16	3.89	4.30
	0.15	1.19	1.72	2.32	3.02	3.82	4.73	5.23
	0.2	1.27	1.90	2.61	3.43	4.36	5.42	6.00
EVR 15	0.1	1.61	2.25	3.00	3.86	4.86	6.00	6.63
	0.15	1.83	2.65	3.58	4.65	5.89	7.29	8.06
	0.2	1.95	2.92	4.03	5.28	6.72	8.35	9.25
EVR 18	0.1	2.11	2.95	3.93	5.06	6.36	7.85	8.67
	0.15	2.40	3.46	4.69	6.09	7.70	9.54	10.55
	0.2	2.56	3.83	5.27	6.92	8.79	10.93	12.10

Capacities are based on liquid temperature $t_l = 25$ °C ahead of evaporator.

The table values refer to the evaporator capacity and are given as a function of evaporating temperature t_e and pressure drop Δp across valve.

Capacities are based on dry, saturated vapour ahead of valve.

During operation with superheated vapour ahead of valve, the capacities are reduced by 4% for each 10 K superheat.

Correction factors

When sizing valves, the evaporator capacity must be multiplied by a correction factor depending on liquid temperature t_l ahead of expansion valve.

When the corrected capacity is known, the selection can be made from the table.

Correction factors for evaporating temperature t_e

t_l [°C]	-40	-30	-20	-10	0	10	15
R134a	0.45	0.61	0.79	1.00	1.25	1.53	1.69

**Extended capacity
Suction**
(continued)

Capacities are based on liquid temperature $t_l = 25\text{ °C}$ ahead of evaporator.

The table values refer to the evaporator capacity and are given as a function of evaporating temperature t_e and pressure drop Δp across valve.

Capacities are based on dry, saturated vapour ahead of valve.

During operation with superheated vapour ahead of valve, the capacities are reduced by 4% for each 10 K superheat.

Type	Pressure drop Δp [bar]	Suction vapour capacity Q_e [kW] at evaporating temperature t_e [°C]						
		-40	-30	-20	-10	0	10	15
R134a (continued)								
EVR 20	0.1	3.35	4.68	6.23	8.02	10.09	12.46	13.76
	0.15	3.81	5.49	7.43	9.66	12.22	15.13	16.74
	0.2	4.06	6.07	8.36	10.97	13.95	17.34	19.20
EVR 22	0.1	3.82	5.34	7.10	9.15	11.51	14.21	15.69
	0.15	4.34	6.27	8.48	11.02	13.94	17.26	19.09
	0.2	4.63	6.92	9.53	12.51	15.91	19.77	21.89
EVR 25	0.2	6.64	9.94	13.68	17.96	22.84	28.38	31.43
EVR 32	0.2	11.35	16.99	23.38	30.69	39.03	48.51	53.71
EVR 40	0.2	16.42	24.57	33.83	44.40	56.46	70.16	77.68

Correction factors

When sizing valves, the evaporator capacity must be multiplied by a correction factor depending on liquid temperature t_l ahead of expansion valve.

When the corrected capacity is known, the selection can be made from the table.

Correction factors for evaporating temperature t_e

t_l [°C]	-40	-30	-20	-10	0	10	15
R134a	0.45	0.61	0.79	1.00	1.25	1.53	1.69

**Extended capacity
Suction**
(continued)

Type	Pressure drop Δp [bar]	Suction vapour capacity Q_e [kW] at evaporating temperature t_e [°C]						
		-40	-30	-20	-10	0	10	15
R404A/R507								
EVR 2	0.1	0.11	0.15	0.19	0.24	0.29	0.36	0.39
	0.15	0.13	0.18	0.23	0.29	0.36	0.44	0.48
	0.2	0.15	0.20	0.26	0.33	0.41	0.50	0.55
EVR 3	0.1	0.20	0.27	0.34	0.43	0.53	0.64	0.71
	0.15	0.24	0.32	0.42	0.52	0.65	0.79	0.86
	0.2	0.27	0.37	0.47	0.60	0.74	0.90	0.99
EVR 4	0.1	0.51	0.67	0.86	1.08	1.33	1.62	1.78
	0.15	0.61	0.81	1.05	1.32	1.63	1.98	2.17
	0.2	0.69	0.92	1.19	1.51	1.87	2.27	2.50
EVR 6	0.1	0.67	0.88	1.13	1.42	1.75	2.12	2.33
	0.15	0.80	1.06	1.37	1.72	2.13	2.59	2.84
	0.2	0.90	1.21	1.56	1.97	2.44	2.98	3.27
EVR 8	0.1	0.80	1.05	1.35	1.69	2.08	2.53	2.77
	0.15	0.95	1.26	1.63	2.05	2.53	3.08	3.38
	0.2	1.07	1.44	1.86	2.35	2.91	3.55	3.89
EVR 10	0.1	1.40	1.85	2.37	2.98	3.67	4.46	4.89
	0.15	1.68	2.23	2.88	3.62	4.47	5.44	5.97
	0.2	1.88	2.53	3.28	4.15	5.13	6.26	6.87
EVR 15	0.1	2.16	2.85	3.66	4.59	5.65	6.87	7.53
	0.15	2.58	3.44	4.43	5.57	6.89	8.38	9.20
	0.2	2.90	3.90	5.06	6.39	7.91	9.63	10.58
EVR 18	0.1	2.83	3.73	4.78	6.00	7.40	8.99	9.86
	0.15	3.38	4.50	5.80	7.30	9.01	10.97	12.04
	0.2	3.80	5.11	6.62	8.36	10.35	12.61	13.85

Capacities are based on liquid temperature $t_l = 25$ °C ahead of evaporator.

The table values refer to the evaporator capacity and are given as a function of evaporating temperature t_e and pressure drop Δp across valve.

Capacities are based on dry, saturated vapour ahead of valve.

During operation with superheated vapour ahead of valve, the capacities are reduced by 4% for each 10 K superheat.

Correction factors

When sizing valves, the evaporator capacity must be multiplied by a correction factor depending on liquid temperature t_l ahead of expansion valve.

When the corrected capacity is known, the selection can be made from the table.

Correction factors for evaporating temperature t_e

t_l [°C]	-40	-30	-20	-10	0	10	15
R404A/R507	0.48	0.63	0.80	1.00	1.23	1.49	1.63

**Extended capacity
Suction**
(continued)

Capacities are based on liquid temperature $t_l = 25\text{ °C}$ ahead of evaporator.

The table values refer to the evaporator capacity and are given as a function of evaporating temperature t_e and pressure drop Δp across valve.

Capacities are based on dry, saturated vapour ahead of valve.

During operation with superheated vapour ahead of valve, the capacities are reduced by 4% for each 10 K superheat.

Type	Pressure drop Δp [bar]	Suction vapour capacity Q_e [kW] at evaporating temperature t_e [°C]						
		-40	-30	-20	-10	0	10	15
R404A/R507 (continued)								
EVR 20	0.1	4.49	5.92	7.59	9.52	11.74	14.26	15.64
	0.15	5.36	7.13	9.20	11.57	14.30	17.39	19.09
	0.2	6.03	8.10	10.50	13.26	16.42	20.01	21.97
EVR 22	0.1	5.12	6.75	8.66	10.86	13.38	16.26	17.84
	0.15	6.11	8.13	10.49	13.20	16.31	19.84	21.78
	0.2	6.87	9.24	11.98	15.13	18.73	22.82	25.06
EVR 25	0.2	9.87	13.26	17.19	21.71	26.88	32.75	35.97
EVR 32	0.2	16.86	22.66	29.38	37.11	45.94	55.97	61.47
EVR 40	0.2	24.39	32.78	42.50	53.68	66.45	80.96	88.92

Correction factors

When sizing valves, the evaporator capacity must be multiplied by a correction factor depending on liquid temperature t_l ahead of expansion valve.

When the corrected capacity is known, the selection can be made from the table.

Correction factors for evaporating temperature t_e

t_l [°C]	-40	-30	-20	-10	0	10	15
R404A/R507	0.48	0.63	0.80	1.00	1.23	1.49	1.63

**Extended capacity
Suction**
(continued)

Type	Pressure drop Δp [bar]	Suction vapour capacity Q_e [kW] at evaporating temperature t_e [°C]						
		-40	-30	-20	-10	0	10	15
R410A								
EVR 2	0.1	0.18	0.22	0.28	0.34	0.41	0.49	0.53
	0.15	0.21	0.27	0.34	0.42	0.50	0.60	0.65
	0.2	0.24	0.31	0.39	0.48	0.58	0.69	0.75
EVR 3	0.1	0.32	0.40	0.51	0.62	0.75	0.89	0.96
	0.15	0.38	0.49	0.61	0.75	0.91	1.08	1.18
	0.2	0.43	0.56	0.70	0.86	1.05	1.25	1.35
EVR 4	0.1	0.80	1.02	1.27	1.56	1.88	2.23	2.42
	0.15	0.96	1.23	1.55	1.90	2.29	2.73	2.96
	0.2	1.09	1.41	1.77	2.18	2.63	3.14	3.41
EVR 6	0.1	1.04	1.33	1.66	2.04	2.46	2.92	3.17
	0.15	1.26	1.62	2.02	2.48	3.00	3.57	3.88
	0.2	1.42	1.84	2.32	2.85	3.45	4.11	4.47
EVR 8	0.1	1.24	1.59	1.98	2.43	2.93	3.48	3.78
	0.15	1.50	1.92	2.41	2.96	3.57	4.25	4.62
	0.2	1.69	2.20	2.76	3.40	4.10	4.89	5.32
EVR 10	0.1	2.19	2.80	3.50	4.28	5.16	6.14	6.67
	0.15	2.64	3.39	4.25	5.22	6.30	7.50	8.15
	0.2	2.99	3.87	4.87	5.99	7.24	8.63	9.38
EVR 15	0.1	3.38	4.32	5.39	6.59	7.95	9.45	10.27
	0.15	4.06	5.23	6.55	8.03	9.70	11.55	12.54
	0.2	4.61	5.96	7.50	9.23	11.15	13.29	14.45
EVR 18	0.1	4.42	5.65	7.05	8.63	10.40	12.38	13.44
	0.15	5.32	6.84	8.57	10.52	12.69	15.11	16.42
	0.2	6.03	7.81	9.82	12.08	14.60	17.40	18.91

Capacities are based on liquid temperature $t_l = 25$ °C ahead of evaporator.

The table values refer to the evaporator capacity and are given as a function of evaporating temperature t_e and pressure drop Δp across valve.

Capacities are based on dry, saturated vapour ahead of valve.

During operation with superheated vapour ahead of valve, the capacities are reduced by 4% for each 10 K superheat.

Correction factors

When sizing valves, the evaporator capacity must be multiplied by a correction factor depending on liquid temperature t_l ahead of expansion valve.

When the corrected capacity is known, the selection can be made from the table.

Correction factors for evaporating temperature t_e

t_l [°C]	-40	-30	-20	-10	0	10	15
R410A	0.52	0.66	0.82	1.00	1.20	1.43	1.55

**Extended capacity
Suction**
(continued)

Capacities are based on liquid temperature $t_l = 25\text{ °C}$ ahead of evaporator.

The table values refer to the evaporator capacity and are given as a function of evaporating temperature t_e and pressure drop Δp across valve.

Capacities are based on dry, saturated vapour ahead of valve.

During operation with superheated vapour ahead of valve, the capacities are reduced by 4% for each 10 K superheat.

Type	Pressure drop Δp [bar]	Suction vapour capacity Q_e [kW] at evaporating temperature t_e [°C]						
		-40	-30	-20	-10	0	10	15
R410A (continued)								
EVR 20	0.1	7.01	8.96	11.19	13.69	16.50	19.63	21.32
	0.15	8.44	10.85	13.59	16.68	20.13	23.97	26.05
	0.2	9.56	12.39	15.57	19.16	23.16	27.60	30.00
EVR 22	0.1	8.00	10.22	12.76	15.62	18.82	22.39	24.31
	0.15	9.62	12.38	15.50	19.02	22.96	27.34	29.71
	0.2	10.91	14.12	17.76	21.85	26.41	31.48	34.22
EVR 25	0.2	15.65	20.28	25.50	31.36	37.91	45.19	49.12
EVR 32	0.2	26.75	34.65	43.57	53.59	64.79	77.22	83.94
EVR 40	0.2	38.70	50.12	63.03	77.52	93.71	111.71	121.42

Correction factors

When sizing valves, the evaporator capacity must be multiplied by a correction factor depending on liquid temperature t_l ahead of expansion valve.

When the corrected capacity is known, the selection can be made from the table.

Correction factors for evaporating temperature t_e

t_l [°C]	-40	-30	-20	-10	0	10	15
R410A	0.52	0.66	0.82	1.00	1.20	1.43	1.55

**Extended capacity
Suction**
(continued)

Type	Pressure drop Δp [bar]	Suction vapour capacity Q_e [kW] at evaporating temperature t_e [°C]						
		-40	-30	-20	-10	0	10	15
R32								
EVR 2	0.1	0.23	0.29	0.36	0.44	0.52	0.62	0.67
	0.15	0.28	0.36	0.44	0.54	0.64	0.75	0.82
	0.2	0.32	0.41	0.51	0.62	0.74	0.87	0.94
EVR 3	0.1	0.42	0.53	0.65	0.79	0.94	1.11	1.20
	0.15	0.50	0.64	0.79	0.96	1.15	1.36	1.47
	0.2	0.57	0.73	0.91	1.11	1.32	1.56	1.69
EVR 4	0.1	1.05	1.33	1.64	1.99	2.38	2.80	3.02
	0.15	1.27	1.61	2.00	2.43	2.90	3.42	3.70
	0.2	1.44	1.84	2.29	2.79	3.34	3.94	4.26
EVR 6	0.1	1.38	1.74	2.15	2.61	3.11	3.66	3.96
	0.15	1.66	2.11	2.62	3.18	3.80	4.47	4.84
	0.2	1.89	2.41	3.00	3.65	4.37	5.15	5.57
EVR 8	0.1	1.64	2.08	2.56	3.10	3.70	4.36	4.72
	0.15	1.98	2.52	3.12	3.78	4.52	5.33	5.76
	0.2	2.25	2.87	3.57	4.35	5.20	6.14	6.64
EVR 10	0.1	2.90	3.66	4.52	5.48	6.53	7.70	8.32
	0.15	3.49	4.44	5.50	6.67	7.97	9.40	10.16
	0.2	3.96	5.07	6.30	7.67	9.18	10.83	11.71
EVR 15	0.1	4.47	5.64	6.96	8.43	10.06	11.85	12.81
	0.15	5.38	6.83	8.46	10.28	12.28	14.48	15.66
	0.2	6.10	7.81	9.70	11.81	14.13	16.68	18.04
EVR 18	0.1	5.84	7.38	9.11	11.04	13.17	15.52	16.77
	0.15	7.04	8.95	11.08	13.45	16.08	18.96	20.49
	0.2	7.99	10.22	12.70	15.46	18.50	21.83	23.61
EVR 20	0.1	9.27	11.71	14.45	17.51	20.89	24.61	26.60
	0.15	11.17	14.19	17.57	21.34	25.50	30.07	32.51
	0.2	12.67	16.21	20.15	24.52	29.34	34.63	37.45
EVR 22	0.1	10.57	13.35	16.48	19.97	23.83	28.07	30.34
	0.15	12.73	16.18	20.04	24.34	29.08	34.29	37.07
	0.2	14.46	18.48	22.98	27.96	33.46	39.49	42.71

Capacities are based on liquid temperature $t_l = 25$ °C ahead of evaporator.

The table values refer to the evaporator capacity and are given as a function of evaporating temperature t_e and pressure drop Δp across valve.

Capacities are based on dry, saturated vapour ahead of valve.

During operation with superheated vapour ahead of valve, the capacities are reduced by 4% for each 10 K superheat.

Correction factors

When sizing valves, the evaporator capacity must be multiplied by a correction factor depending on liquid temperature t_l ahead of expansion valve.

When the corrected capacity is known, the selection can be made from the table.

Correction factors for evaporating temperature t_e

t_l [°C]	-40	-30	-20	-10	0	10	15
R32	0.54	0.67	0.83	1.00	1.19	1.40	1.51

**Extended capacity
Suction**
(continued)

Type	Pressure drop Δp [bar]	Suction vapour capacity Q_e [kW] at evaporating temperature t_e [°C]						
		-40	-30	-20	-10	0	10	15
R290								
EVR 2	0.1	0.17	0.22	0.27	0.34	0.41	0.49	0.53
	0.15	0.20	0.26	0.33	0.41	0.50	0.60	0.65
	0.2	0.22	0.29	0.38	0.47	0.57	0.68	0.75
EVR 3	0.1	0.30	0.39	0.49	0.61	0.73	0.88	0.96
	0.15	0.36	0.47	0.59	0.73	0.89	1.07	1.17
	0.2	0.40	0.53	0.68	0.84	1.03	1.23	1.35
EVR 4	0.1	0.76	0.98	1.24	1.52	1.85	2.22	2.42
	0.15	0.90	1.18	1.49	1.85	2.25	2.70	2.95
	0.2	1.01	1.33	1.70	2.12	2.58	3.10	3.39
EVR 6	0.1	0.99	1.29	1.62	2.00	2.42	2.90	3.16
	0.15	1.18	1.54	1.95	2.42	2.95	3.54	3.86
	0.2	1.32	1.75	2.23	2.77	3.38	4.06	4.43
EVR 8	0.1	1.18	1.53	1.93	2.38	2.89	3.46	3.77
	0.15	1.41	1.84	2.33	2.88	3.51	4.21	4.59
	0.2	1.57	2.08	2.65	3.30	4.03	4.84	5.28
EVR 10	0.1	2.09	2.70	3.40	4.19	5.09	6.10	6.64
	0.15	2.48	3.24	4.11	5.09	6.19	7.43	8.10
	0.2	2.78	3.67	4.68	5.82	7.10	8.54	9.32
EVR 15	0.1	3.22	4.16	5.23	6.46	7.84	9.39	10.23
	0.15	3.82	4.99	6.33	7.83	9.54	11.44	12.48
	0.2	4.28	5.65	7.21	8.96	10.94	13.15	14.35
EVR 18	0.1	4.21	5.44	6.85	8.45	10.26	12.29	13.40
	0.15	5.01	6.54	8.28	10.26	12.48	14.98	16.34
	0.2	5.60	7.40	9.43	11.73	14.32	17.21	18.78
EVR 20	0.1	6.68	8.63	10.87	13.41	16.28	19.50	21.25
	0.15	7.94	10.37	13.13	16.27	19.80	23.76	25.91
	0.2	8.88	11.73	14.96	18.61	22.71	27.30	29.79
EVR 22	0.1	7.62	9.85	12.39	15.29	18.56	22.24	24.23
	0.15	9.06	11.83	14.98	18.55	22.58	27.10	29.55
	0.2	10.13	13.38	17.06	21.22	25.90	31.13	33.97

Capacities are based on liquid temperature $t_l = 25$ °C ahead of evaporator.

The table values refer to the evaporator capacity and are given as a function of evaporating temperature t_e and pressure drop Δp across valve.

Capacities are based on dry, saturated vapour ahead of valve.

During operation with superheated vapour ahead of valve, the capacities are reduced by 4% for each 10 K superheat.

Correction factors

When sizing valves, the evaporator capacity must be multiplied by a correction factor depending on liquid temperature t_l ahead of expansion valve.

When the corrected capacity is known, the selection can be made from the table.

Correction factors for evaporating temperature t_e

t_l [°C]	-40	-30	-20	-10	0	10	15
R290	0.51	0.65	0.82	1.00	1.21	1.44	1.57

**Extended capacity
Suction**
(continued)

Type	Pressure drop Δp [bar]	Suction vapour capacity Q_e [kW] at evaporating temperature t_e [°C]						
		-40	-30	-20	-10	0	10	15
R600a								
EVR 2	0.1	0.07	0.11	0.15	0.19	0.24	0.30	0.34
	0.15	0.08	0.12	0.17	0.23	0.29	0.36	0.41
	0.2	0.08	0.13	0.19	0.25	0.33	0.41	0.46
EVR 3	0.1	0.13	0.19	0.26	0.34	0.44	0.54	0.60
	0.15	0.14	0.22	0.31	0.41	0.52	0.66	0.73
	0.2	0.14	0.23	0.34	0.46	0.59	0.75	0.83
EVR 4	0.1	0.33	0.48	0.66	0.87	1.10	1.37	1.52
	0.15	0.34	0.54	0.77	1.03	1.32	1.65	1.84
	0.2	0.34	0.57	0.84	1.15	1.49	1.88	2.09
EVR 6	0.1	0.43	0.63	0.87	1.14	1.44	1.80	1.99
	0.15	0.45	0.71	1.01	1.35	1.73	2.17	2.40
	0.2	0.45	0.75	1.10	1.50	1.95	2.46	2.74
EVR 8	0.1	0.51	0.75	1.03	1.35	1.72	2.14	2.37
	0.15	0.53	0.85	1.20	1.60	2.06	2.58	2.86
	0.2	0.53	0.89	1.32	1.79	2.33	2.93	3.26
EVR 10	0.1	0.90	1.33	1.82	2.39	3.03	3.77	4.18
	0.15	0.94	1.50	2.12	2.83	3.63	4.55	5.05
	0.2	0.94	1.58	2.32	3.16	4.10	5.17	5.76
EVR 15	0.1	1.39	2.05	2.81	3.67	4.67	5.81	6.43
	0.15	1.45	2.31	3.27	4.36	5.60	7.01	7.78
	0.2	1.45	2.43	3.57	4.86	6.32	7.97	8.87
EVR 18	0.1	1.82	2.68	3.67	4.81	6.11	7.60	8.42
	0.15	1.90	3.02	4.27	5.70	7.33	9.17	10.18
	0.2	1.90	3.18	4.68	6.37	8.27	10.43	11.61
EVR 20	0.1	2.89	4.26	5.83	7.63	9.70	12.06	13.36
	0.15	3.02	4.79	6.78	9.04	11.62	14.55	16.15
	0.2	3.02	5.04	7.42	10.10	13.12	16.54	18.41
EVR 22	0.1	3.30	4.86	6.64	8.70	11.06	13.76	15.24
	0.15	3.44	5.46	7.73	10.31	13.25	16.59	18.42
	0.2	3.44	5.74	8.46	11.52	14.97	18.86	20.99

Capacities are based on liquid temperature $t_l = 25$ °C ahead of evaporator.

The table values refer to the evaporator capacity and are given as a function of evaporating temperature t_e and pressure drop Δp across valve.

Capacities are based on dry, saturated vapour ahead of valve.

During operation with superheated vapour ahead of valve, the capacities are reduced by 4% for each 10 K superheat.

Correction factors

When sizing valves, the evaporator capacity must be multiplied by a correction factor depending on liquid temperature t_l ahead of expansion valve.

When the corrected capacity is known, the selection can be made from the table.

Correction factors for evaporating temperature t_e

t_e [°C]	-40	-30	-20	-10	0	10	15
R600a	0.44	0.60	0.78	1.00	1.25	1.54	1.70

**Extended capacity
Suction**
(continued)

Hot gas defrosting

With hot gas defrosting, it is not normally possible to select a valve from condensing temperature t_c and evaporating temperature t_e .

This is because as a rule, the pressure in the evaporator quickly rises to a value near that of the condensing pressure. It remains at this value until the defrosting is finished.

In most cases, the valve will be selected from condensing temperature t_c and pressure drop Δp across the valve, as shown in the example for heat recovery.

Heat recovery

The following is given:

- Refrigerant = R22/R407C
- Evaporating temperature $t_e = -30\text{ °C}$
- Condensing temperature $t_c = 40\text{ °C}$
- Hot gas temperature ahead of valve $t_h = 85\text{ °C}$
- Heat recovery condenser yield $Q_h = 8\text{ kW}$

The capacity table for R22/R407C with $t_c = 40\text{ °C}$ gives the capacity for an EVR 10 as 8.6 kW, when pressure drop Δp is 0.2 bar. The required capacity is calculated as:

$$Q_{table} = f_{evaporator} \times f_{hot_temperature} \times Q_h$$

The correction factor for $t_e = -30\text{ °C}$ is given in the table as 0.95.

The correction for hot gas temperature $t_h = 85\text{ °C}$ has been calculated as 4% which corresponds to a factor of 1.04.

Q_h must be corrected with factors found:
 $8 \times 0.95 \times 1.04 = 7.91\text{ kW}$.

EVR 10, with $\Delta p = 0.2\text{ bar}$, $Q_{table} = 8.6\text{ kW}$.

EVR 10, with $\Delta p = 0.1\text{ bar}$, $Q_{table} = 6.1\text{ kW}$.

An EVR 6 would also be able to give the required capacity, but with Δp at approximately 0.8 bar, the EVR 6 is therefore too small.

The EVR 15 is so large that it is doubtful whether the necessary Δp of approximately 0.1 bar could be obtained.

An EVR 15 would therefore be too large.

Result: An EVR 10 is the correct valve for the given conditions.

Capacity Hot gas

Type	Pressure drop across valve Δp [bar]	Hot gas capacity Q_h [kW]. Evaporating temp. $t_e = -10.0$ [°C]. Hot gas temp. $t_h = t_c + 25.0$ [K]. Subcooling $\Delta t_{sub} = 4.0$ [K]				
		Condensing temperature t_c [°C]				
		20	30	40	50	60
R22/R407C						
EVR 2	0.1	0.44	0.47	0.49	0.51	0.51
	0.2	0.61	0.66	0.69	0.71	0.72
	0.3	0.75	0.80	0.84	0.87	0.88
	0.4	0.86	0.92	0.97	1.00	1.02
	0.8	1.18	1.27	1.35	1.40	1.43
	1.6	1.57	1.72	1.84	1.93	1.98
EVR 3	0.1	0.79	0.84	0.88	0.91	0.92
	0.2	1.11	1.18	1.24	1.28	1.30
	0.3	1.35	1.44	1.51	1.57	1.59
	0.4	1.54	1.65	1.74	1.80	1.83
	0.8	2.12	2.29	2.42	2.52	2.57
	1.6	2.83	3.10	3.32	3.47	3.56
EVR 4	0.1	1.98	2.11	2.22	2.29	2.33
	0.2	2.79	2.97	3.13	3.23	3.28
	0.3	3.39	3.62	3.81	3.95	4.01
	0.4	3.89	4.16	4.39	4.54	4.62
	0.8	5.35	5.77	6.10	6.34	6.47
	1.6	7.14	7.81	8.35	8.74	8.96
EVR 6	0.1	2.60	2.77	2.90	3.00	3.05
	0.2	3.65	3.89	4.09	4.23	4.30
	0.3	4.44	4.74	4.99	5.17	5.25
	0.4	5.09	5.45	5.74	5.95	6.05
	0.8	7.00	7.55	7.99	8.30	8.47
	1.6	9.34	10.22	10.93	11.44	11.73
EVR 8	0.1	3.09	3.30	3.46	3.58	3.63
	0.2	4.34	4.64	4.87	5.04	5.12
	0.3	5.28	5.65	5.94	6.15	6.25
	0.4	6.06	6.49	6.84	7.08	7.20
	0.8	8.34	8.99	9.51	9.89	10.08
	1.6	11.13	12.17	13.02	13.63	13.97

An increase in hot gas temperature t_h of 10 K, based on $t_h = t_c + 25$ °C, reduces valve capacity approx. 2% and vice versa.

A change in evaporating temperature t_e changes valve capacity; see correction factor table.

Correction factors

When sizing valves, the required capacity Hot gas must be multiplied by a correction factor depending on evaporating temperature t_e .

Correction factors for evaporating temperature t_e

t_e [°C]	-40	-30	-20	-10	0	10	15
R22	0.92	0.95	0.98	1.00	1.02	1.04	1.05
R407C	0.90	0.94	0.97	1.00	1.03	1.06	1.07

**Extended capacity
Hot gas**
(continued)

Type	Pressure drop across valve Δp [bar]	Hot gas capacity Q_h [kW]. Evaporating temp. $t_e = -10.0$ [°C]. Hot gas temp. $t_h = t_c + 25.0$ [K]. Subcooling $\Delta t_{sub} = 4.0$ [K]				
		Condensing temperature t_c [°C]				
		20	30	40	50	60
R22/R407C (continued)						
EVR 10	0.1	5.45	5.81	6.10	6.31	6.40
	0.2	7.66	8.18	8.60	8.89	9.03
	0.3	9.32	9.97	10.49	10.86	11.03
	0.4	10.69	11.45	12.06	12.50	12.71
	0.8	14.71	15.86	16.78	17.45	17.79
	1.6	19.63	21.48	22.96	24.05	24.64
EVR 15	0.1	8.40	8.95	9.40	9.71	9.86
	0.2	11.80	12.60	13.24	13.69	13.91
	0.3	14.36	15.35	16.15	16.72	16.99
	0.4	16.46	17.63	18.58	19.24	19.57
	0.8	22.65	24.42	25.85	26.87	27.39
	1.6	30.23	33.08	35.37	37.03	37.95
EVR 18	0.1	11.00	11.72	12.30	12.71	12.90
	0.2	15.45	16.49	17.33	17.93	18.20
	0.3	18.79	20.09	21.14	21.89	22.24
	0.4	21.55	23.08	24.32	25.19	25.61
	0.8	29.65	31.97	33.84	35.18	35.86
	1.6	39.57	43.30	46.30	48.48	49.68
EVR 20	0.1	17.44	18.59	19.52	20.17	20.47
	0.2	24.50	26.16	27.49	28.43	28.87
	0.3	29.81	31.87	33.54	34.71	35.27
	0.4	34.19	36.61	38.57	39.96	40.63
	0.8	47.03	50.71	53.68	55.80	56.88
	1.6	62.77	68.68	73.44	76.90	78.81
EVR 22	0.1	19.89	21.20	22.26	23.00	23.34
	0.2	27.95	29.83	31.36	32.43	32.93
	0.3	34.00	36.35	38.25	39.59	40.23
	0.4	38.99	41.76	43.99	45.57	46.34
	0.8	53.63	57.83	61.22	63.64	64.87
	1.6	71.59	78.32	83.75	87.70	89.87

An increase in hot gas temperature t_h of 10 K, based on $t_h = t_c + 25$ °C, reduces valve capacity approx. 2% and vice versa.

A change in evaporating temperature t_e changes valve capacity; see correction factor table.

Correction factors

When sizing valves, the required capacity Hot gas must be multiplied by a correction factor depending on evaporating temperature t_e .

Correction factors for evaporating temperature t_e

t_e [°C]	-40	-30	-20	-10	0	10	15
R22	0.92	0.95	0.98	1.00	1.02	1.04	1.05
R407C	0.90	0.94	0.97	1.00	1.03	1.06	1.07

**Extended capacity
Hot gas**
(continued)

Type	Pressure drop across valve Δp [bar]	Hot gas capacity Qh [kW]. Evaporating temp. $t_e = -10.0$ [°C]. Hot gas temp. $t_h = t_c + 25.0$ [K]. Subcooling $\Delta t_{sub} = 4.0$ [K]				
		Condensing temperature t_c [°C]				
		20	30	40	50	60
R22/R407C (continued)						
EVR 25	0.2	40.12	42.82	45.01	46.55	47.27
	0.3	48.80	52.18	54.91	56.83	57.75
	0.4	55.97	59.94	63.15	65.42	66.52
	0.8	76.99	83.01	87.87	91.35	93.12
	1.6	102.77	112.43	120.23	125.89	129.01
EVR 32	0.2	68.55	73.18	76.92	79.55	80.78
	0.3	83.39	89.17	93.83	97.12	98.69
	0.4	95.64	102.43	107.91	111.79	113.67
	0.8	131.57	141.86	150.17	156.11	159.13
	1.6	175.62	192.14	205.45	215.13	220.47
EVR 40	0.2	99.16	105.86	111.26	115.07	116.85
	0.3	120.63	128.98	135.72	140.49	142.75
	0.4	138.35	148.17	156.10	161.71	164.42
	0.8	190.31	205.20	217.22	225.81	230.18
	1.6	254.03	277.93	297.19	311.19	318.91

An increase in hot gas temperature t_h of 10 K, based on $t_h = t_c + 25$ °C, reduces valve capacity approx. 2% and vice versa.

A change in evaporating temperature t_e changes valve capacity; see correction factor table.

Correction factors

When sizing valves, the required capacity Hot gas must be multiplied by a correction factor depending on evaporating temperature t_e .

Correction factors for evaporating temperature t_e

t_e [°C]	-40	-30	-20	-10	0	10	15
R22	0.92	0.95	0.98	1.00	1.02	1.04	1.05
R407C	0.90	0.94	0.97	1.00	1.03	1.06	1.07

**Extended capacity
Hot gas**
(continued)

Type	Pressure drop across valve Δp [bar]	Hot gas capacity Qh [kW]. Evaporating temp. $t_e = -10.0$ [°C]. Hot gas temp. $t_h = t_c + 25.0$ [K]. Subcooling $\Delta t_{sub} = 4.0$ [K]				
		Condensing temperature t_c [°C]				
		20	30	40	50	60
R134a						
EVR 2	0.1	0.35	0.37	0.38	0.39	0.39
	0.2	0.48	0.52	0.54	0.55	0.55
	0.3	0.59	0.63	0.66	0.67	0.67
	0.4	0.67	0.72	0.75	0.77	0.77
	0.8	0.90	0.98	1.04	1.07	1.07
	1.6	1.15	1.29	1.39	1.45	1.47
EVR 3	0.1	0.62	0.66	0.69	0.70	0.70
	0.2	0.87	0.93	0.97	0.99	0.99
	0.3	1.06	1.13	1.18	1.21	1.20
	0.4	1.21	1.29	1.36	1.39	1.39
	0.8	1.63	1.77	1.87	1.93	1.93
	1.6	2.07	2.32	2.50	2.61	2.64
EVR 4	0.1	1.57	1.67	1.74	1.78	1.77
	0.2	2.20	2.34	2.45	2.50	2.49
	0.3	2.66	2.85	2.98	3.04	3.03
	0.4	3.04	3.26	3.42	3.50	3.49
	0.8	4.09	4.45	4.70	4.85	4.86
	1.6	5.22	5.84	6.30	6.58	6.66
EVR 6	0.1	2.06	2.19	2.28	2.32	2.31
	0.2	2.88	3.07	3.20	3.27	3.26
	0.3	3.48	3.72	3.90	3.98	3.97
	0.4	3.98	4.26	4.47	4.58	4.57
	0.8	5.36	5.82	6.16	6.35	6.36
	1.6	6.83	7.65	8.24	8.61	8.71
EVR 8	0.1	2.45	2.60	2.71	2.77	2.75
	0.2	3.43	3.65	3.81	3.89	3.88
	0.3	4.15	4.44	4.64	4.75	4.73
	0.4	4.73	5.08	5.32	5.45	5.44
	0.8	6.38	6.93	7.33	7.56	7.57
	1.6	8.14	9.11	9.82	10.26	10.38

An increase in hot gas temperature t_h of 10 K, based on $t_h = t_c + 25$ °C, reduces valve capacity approx. 2% and vice versa.

A change in evaporating temperature t_e changes valve capacity; see correction factor table.

Correction factors

When sizing valves, the required capacity Hot gas must be multiplied by a correction factor depending on evaporating temperature t_e .

Correction factors for evaporating temperature t_e

t_e [°C]	-40	-30	-20	-10	0	10	15
R134a	0.88	0.92	0.96	1.00	1.04	1.08	1.09

**Extended capacity
Hot gas**
(continued)

Type	Pressure drop across valve Δp [bar]	Hot gas capacity Qh [kW]. Evaporating temp. $t_e = -10.0$ [°C]. Hot gas temp. $t_h = t_c + 25.0$ [K]. Subcooling $\Delta t_{sub} = 4.0$ [K]				
		Condensing temperature t_c [°C]				
		20	30	40	50	60
R134a (continued)						
EVR 10	0.1	4.32	4.60	4.79	4.88	4.85
	0.2	6.05	6.44	6.73	6.87	6.84
	0.3	7.32	7.83	8.19	8.37	8.34
	0.4	8.35	8.96	9.39	9.62	9.60
	0.8	11.26	12.23	12.94	13.33	13.36
	1.6	14.35	16.06	17.32	18.09	18.30
EVR 15	0.1	6.66	7.08	7.37	7.52	7.48
	0.2	9.31	9.92	10.36	10.58	10.53
	0.3	11.27	12.05	12.61	12.89	12.85
	0.4	12.86	13.80	14.46	14.81	14.78
	0.8	17.34	18.84	19.93	20.54	20.58
	1.6	22.10	24.74	26.68	27.86	28.19
EVR 18	0.1	8.72	9.26	9.65	9.84	9.79
	0.2	12.19	12.99	13.56	13.85	13.79
	0.3	14.76	15.78	16.50	16.88	16.82
	0.4	16.84	18.06	18.93	19.39	19.35
	0.8	22.70	24.66	26.08	26.88	26.94
	1.6	28.93	32.39	34.93	36.48	36.90
EVR 20	0.1	13.83	14.69	15.31	15.61	15.52
	0.2	19.33	20.61	21.51	21.97	21.87
	0.3	23.41	25.02	26.18	26.77	26.68
	0.4	26.71	28.65	30.03	30.76	30.69
	0.8	36.00	39.12	41.37	42.64	42.73
	1.6	45.89	51.37	55.40	57.86	58.53
EVR 22	0.1	15.77	16.76	17.46	17.80	17.71
	0.2	22.05	23.50	24.53	25.05	24.94
	0.3	26.69	28.54	29.85	30.53	30.43
	0.4	30.46	32.67	34.25	35.08	35.00
	0.8	41.06	44.61	47.18	48.63	48.74
	1.6	52.34	58.59	63.18	65.98	66.75

An increase in hot gas temperature t_h of 10 K, based on $t_h = t_c + 25$ °C, reduces valve capacity approx. 2% and vice versa.

A change in evaporating temperature t_e changes valve capacity; see correction factor table.

Correction factors

When sizing valves, the required capacity Hot gas must be multiplied by a correction factor depending on evaporating temperature t_e .

Correction factors for evaporating temperature t_e

t_e [°C]	-40	-30	-20	-10	0	10	15
R134a	0.88	0.92	0.96	1.00	1.04	1.08	1.09

**Extended capacity
Hot gas**
(continued)

An increase in hot gas temperature t_h of 10 K, based on $t_h = t_c + 25$ °C, reduces valve capacity approx. 2% and vice versa.

A change in evaporating temperature t_e changes valve capacity; see correction factor table.

Type	Pressure drop across valve Δp [bar]	Hot gas capacity Qh [kW]. Evaporating temp. $t_e = -10.0$ [°C]. Hot gas temp. $t_h = t_c + 25.0$ [K]. Subcooling $\Delta t_{sub} = 4.0$ [K]				
		Condensing temperature t_c [°C]				
		20	30	40	50	60
R134a (continued)						
EVR 25	0.2	31.65	33.74	35.22	35.96	35.81
	0.3	38.32	40.97	42.86	43.83	43.68
	0.4	43.73	46.90	49.17	50.36	50.25
	0.8	58.94	64.04	67.73	69.81	69.96
	1.6	75.14	84.10	90.69	94.72	95.82
EVR 32	0.2	54.08	57.65	60.18	61.46	61.19
	0.3	65.48	70.01	73.24	74.90	74.65
	0.4	74.73	80.15	84.02	86.06	85.87
	0.8	100.72	109.44	115.75	119.29	119.55
	1.6	128.40	143.72	154.99	161.86	163.75
EVR 40	0.2	78.23	83.39	87.05	88.90	88.51
	0.3	94.72	101.27	105.94	108.34	107.99
	0.4	108.10	115.93	121.54	124.49	124.21
	0.8	145.69	158.31	167.43	172.55	172.94
	1.6	185.73	207.90	224.19	234.14	236.87

Correction factors

When sizing valves, the required capacity Hot gas must be multiplied by a correction factor depending on evaporating temperature t_e .

Correction factors for evaporating temperature t_e

t_e [°C]	-40	-30	-20	-10	0	10	15
R134a	0.88	0.92	0.96	1.00	1.04	1.08	1.09

**Extended capacity
Hot gas**
(continued)

Type	Pressure drop across valve Δp bar	Hot gas capacity Qh [kW]. Evaporating temp. $t_e = -10.0$ [°C]. Hot gas temp. $t_h = t_c + 25.0$ [K]. Subcooling $\Delta t_{sub} = 4.0$ [K]				
		Condensing temperature t_c [°C]				
		20	30	40	50	60
R404A/R507						
EVR 2	0.1	0.40	0.40	0.40	0.38	0.34
	0.2	0.56	0.57	0.56	0.54	0.49
	0.3	0.68	0.69	0.69	0.66	0.59
	0.4	0.78	0.80	0.79	0.76	0.68
	0.8	1.07	1.11	1.10	1.06	0.96
	1.6	1.44	1.50	1.52	1.47	1.33
EVR 3	0.1	0.71	0.73	0.72	0.69	0.62
	0.2	1.00	1.02	1.02	0.97	0.88
	0.3	1.22	1.25	1.24	1.19	1.07
	0.4	1.40	1.43	1.43	1.37	1.23
	0.8	1.93	1.99	1.99	1.91	1.73
	1.6	2.60	2.71	2.73	2.64	2.40
EVR 4	0.1	1.79	1.83	1.82	1.74	1.56
	0.2	2.52	2.57	2.56	2.45	2.20
	0.3	3.07	3.14	3.12	2.99	2.69
	0.4	3.52	3.61	3.59	3.44	3.10
	0.8	4.86	5.01	5.01	4.82	4.35
	1.6	6.54	6.82	6.88	6.66	6.04
EVR 6	0.1	2.35	2.39	2.38	2.27	2.04
	0.2	3.30	3.37	3.35	3.21	2.89
	0.3	4.02	4.11	4.09	3.92	3.53
	0.4	4.61	4.72	4.70	4.51	4.06
	0.8	6.36	6.56	6.56	6.30	5.69
	1.6	8.56	8.93	9.00	8.71	7.91
EVR 8	0.1	2.79	2.85	2.83	2.71	2.44
	0.2	3.93	4.01	3.99	3.82	3.44
	0.3	4.78	4.89	4.87	4.66	4.20
	0.4	5.49	5.62	5.60	5.37	4.84
	0.8	7.58	7.81	7.81	7.51	6.78
	1.6	10.20	10.63	10.72	10.38	9.42

An increase in hot gas temperature t_h of 10 K, based on $t_h = t_c + 25$ °C, reduces valve capacity approx. 2% and vice versa.

A change in evaporating temperature t_e changes valve capacity; see correction factor table.

Correction factors

When sizing valves, the required capacity Hot gas must be multiplied by a correction factor depending on evaporating temperature t_e .

Correction factors for evaporating temperature t_e

t_e [°C]	-40	-30	-20	-10	0	10	15
R404A/R507	0.86	0.91	0.96	1.00	1.04	1.08	1.10

**Extended capacity
Hot gas**
(continued)

Type	Pressure drop across valve Δp bar	Hot gas capacity Qh [kW]. Evaporating temp. $t_e = -10.0$ [°C]. Hot gas temp. $t_h = t_c + 25.0$ [K]. Subcooling $\Delta t_{sub} = 4.0$ [K]				
		Condensing temperature t_c [°C]				
		20	30	40	50	60
R404A/R507 (continued)						
EVR 10	0.1	4.93	5.03	4.99	4.78	4.30
	0.2	6.93	7.08	7.04	6.74	6.06
	0.3	8.44	8.63	8.59	8.23	7.41
	0.4	9.69	9.92	9.88	9.47	8.54
	0.8	13.37	13.78	13.78	13.25	11.96
	1.6	17.99	18.76	18.92	18.31	16.61
EVR 15	0.1	7.59	7.75	7.69	7.36	6.62
	0.2	10.67	10.90	10.84	10.37	9.34
	0.3	13.00	13.29	13.23	12.67	11.41
	0.4	14.92	15.28	15.22	14.59	13.14
	0.8	20.59	21.22	21.22	20.40	18.42
	1.6	27.70	28.89	29.14	28.20	25.58
EVR 18	0.1	9.94	10.14	10.07	9.63	8.66
	0.2	13.97	14.27	14.19	13.58	12.22
	0.3	17.01	17.40	17.31	16.59	14.94
	0.4	19.53	20.00	19.92	19.10	17.21
	0.8	26.96	27.78	27.77	26.71	24.12
	1.6	36.26	37.82	38.14	36.91	33.49
EVR 20	0.1	15.76	16.08	15.97	15.27	13.74
	0.2	22.16	22.64	22.50	21.54	19.39
	0.3	26.98	27.61	27.46	26.31	23.69
	0.4	30.97	31.73	31.60	30.29	27.29
	0.8	42.76	44.06	44.05	42.36	38.25
	1.6	57.52	59.99	60.50	58.55	53.12
EVR 22	0.1	17.98	18.34	18.21	17.42	15.67
	0.2	25.28	25.82	25.66	24.57	22.11
	0.3	30.77	31.48	31.32	30.00	27.02
	0.4	35.32	36.19	36.04	34.55	31.13
	0.8	48.77	50.25	50.24	48.31	43.63
	1.6	65.60	68.42	69.00	66.77	60.58

An increase in hot gas temperature t_h of 10 K, based on $t_h = t_c + 25$ °C, reduces valve capacity approx. 2% and vice versa.

A change in evaporating temperature t_e changes valve capacity; see correction factor table.

Correction factors

When sizing valves, the required capacity Hot gas must be multiplied by a correction factor depending on evaporating temperature t_e .

Correction factors for evaporating temperature t_e

t_e [°C]	-40	-30	-20	-10	0	10	15
R404A/R507	0.86	0.91	0.96	1.00	1.04	1.08	1.10

**Extended capacity
Hot gas**
(continued)

An increase in hot gas temperature t_h of 10 K, based on $t_h = t_c + 25$ °C, reduces valve capacity approx. 2% and vice versa.

A change in evaporating temperature t_e changes valve capacity; see correction factor table.

Type	Pressure drop across valve Δp bar	Hot gas capacity Qh [kW]. Evaporating temp. $t_e = -10.0$ [°C]. Hot gas temp. $t_h = t_c + 25.0$ [K]. Subcooling $\Delta t_{sub} = 4.0$ [K]				
		Condensing temperature t_c [°C]				
		20	30	40	50	60
R404A/R507 (continued)						
EVR 25	0.2	36.28	37.07	36.84	35.26	31.74
	0.3	44.17	45.19	44.96	43.07	38.78
	0.4	50.71	51.95	51.73	49.59	44.68
	0.8	70.00	72.13	72.12	69.35	62.63
	1.6	94.17	98.22	99.05	95.85	86.97
EVR 32	0.2	62.00	63.34	62.95	60.26	54.24
	0.3	75.49	77.23	76.83	73.60	66.28
	0.4	86.65	88.77	88.40	84.75	76.36
	0.8	119.62	123.26	123.24	118.51	107.02
	1.6	160.92	167.84	169.27	163.80	148.61
EVR 40	0.2	89.69	91.63	91.06	87.17	78.45
	0.3	109.20	111.71	111.13	106.46	95.87
	0.4	125.34	128.41	127.87	122.59	110.45
	0.8	173.04	178.29	178.27	171.43	154.81
	1.6	232.77	242.78	244.85	236.94	214.97

Correction factors

When sizing valves, the required capacity Hot gas must be multiplied by a correction factor depending on evaporating temperature t_e .

Correction factors for evaporating temperature t_e

t_e [°C]	-40	-30	-20	-10	0	10	15
R404A/R507	0.86	0.91	0.96	1.00	1.04	1.08	1.10

**Extended capacity
Hot gas**
(continued)

Type	Pressure drop across valve Δp bar	Hot gas capacity Qh [kW]. Evaporating temp. $t_e = -10.0$ [°C]. Hot gas temp. $t_h = t_c + 25.0$ [K]. Subcooling $\Delta t_{sub} = 4.0$ [K]				
		Condensing temperature t_c [°C]				
		20	30	40	50	60
R410A						
EVR 2	0.1	0.55	0.58	0.60	0.60	0.58
	0.2	0.78	0.81	0.84	0.84	0.82
	0.3	0.95	0.99	1.03	1.03	1.00
	0.4	1.09	1.14	1.18	1.19	1.15
	0.8	1.51	1.60	1.65	1.67	1.61
	1.6	2.06	2.20	2.29	2.32	2.25
EVR 3	0.1	0.99	1.04	1.07	1.08	1.04
	0.2	1.40	1.47	1.51	1.52	1.47
	0.3	1.70	1.79	1.85	1.86	1.79
	0.4	1.96	2.06	2.13	2.14	2.07
	0.8	2.72	2.88	2.98	3.00	2.91
	1.6	3.71	3.96	4.12	4.17	4.06
EVR 4	0.1	2.50	2.62	2.70	2.71	2.62
	0.2	3.51	3.69	3.81	3.82	3.70
	0.3	4.29	4.51	4.65	4.67	4.52
	0.4	4.93	5.19	5.35	5.39	5.21
	0.8	6.85	7.24	7.50	7.56	7.32
	1.6	9.35	9.97	10.38	10.51	10.22
EVR 6	0.1	3.27	3.43	3.53	3.55	3.43
	0.2	4.60	4.83	4.98	5.00	4.84
	0.3	5.61	5.90	6.08	6.12	5.91
	0.4	6.45	6.79	7.01	7.05	6.82
	0.8	8.96	9.48	9.81	9.89	9.58
	1.6	12.23	13.05	13.59	13.76	13.38
EVR 8	0.1	3.89	4.08	4.21	4.22	4.08
	0.2	5.48	5.76	5.93	5.96	5.76
	0.3	6.68	7.03	7.25	7.29	7.04
	0.4	7.68	8.09	8.35	8.40	8.12
	0.8	10.67	11.29	11.68	11.78	11.41
	1.6	14.57	15.54	16.18	16.39	15.93

An increase in hot gas temperature t_h of 10 K, based on $t_h = t_c + 25$ °C, reduces valve capacity approx. 2% and vice versa.

A change in evaporating temperature t_e changes valve capacity; see correction factor table.

Correction factors

When sizing valves, the required capacity Hot gas must be multiplied by a correction factor depending on evaporating temperature t_e .

Correction factors for evaporating temperature t_e

t_e [°C]	-40	-30	-20	-10	0	10	15
R410A	0.93	0.95	0.98	1.00	1.02	1.03	1.04

**Extended capacity
Hot gas**
(continued)

Type	Pressure drop across valve Δp bar	Hot gas capacity Qh [kW]. Evaporating temp. $t_e = -10.0$ [°C]. Hot gas temp. $t_h = t_c + 25.0$ [K]. Subcooling $\Delta t_{sub} = 4.0$ [K]				
		Condensing temperature t_c [°C]				
		20	30	40	50	60
R410A (continued)						
EVR 10	0.1	6.86	7.20	7.42	7.45	7.20
	0.2	9.66	10.16	10.46	10.52	10.16
	0.3	11.78	12.40	12.78	12.85	12.43
	0.4	13.55	14.27	14.72	14.81	14.33
	0.8	18.83	19.91	20.61	20.78	20.13
	1.6	25.70	27.41	28.55	28.91	28.10
EVR 15	0.1	10.57	11.10	11.43	11.48	11.09
	0.2	14.88	15.64	16.12	16.20	15.65
	0.3	18.15	19.09	19.69	19.80	19.14
	0.4	20.87	21.98	22.68	22.81	22.07
	0.8	29.00	30.67	31.74	32.00	31.00
	1.6	39.58	42.22	43.97	44.53	43.28
EVR 18	0.1	13.83	14.52	14.96	15.02	14.51
	0.2	19.48	20.47	21.10	21.20	20.49
	0.3	23.76	24.99	25.77	25.91	25.05
	0.4	27.32	28.77	29.69	29.86	28.88
	0.8	37.97	40.15	41.55	41.89	40.59
	1.6	51.81	55.27	57.56	58.29	56.66
EVR 20	0.1	21.94	23.04	23.72	23.83	23.02
	0.2	30.90	32.48	33.46	33.63	32.50
	0.3	37.68	39.65	40.88	41.10	39.74
	0.4	43.33	45.63	47.09	47.37	45.82
	0.8	60.22	63.68	65.91	66.45	64.38
	1.6	82.19	87.67	91.30	92.46	89.87
EVR 22	0.1	25.03	26.28	27.06	27.17	26.25
	0.2	35.24	37.04	38.17	38.35	37.07
	0.3	42.98	45.22	46.62	46.88	45.32
	0.4	49.41	52.04	53.70	54.02	52.25
	0.8	68.68	72.63	75.17	75.79	73.42
	1.6	93.73	99.98	104.12	105.44	102.49

An increase in hot gas temperature t_h of 10 K, based on $t_h = t_c + 25$ °C, reduces valve capacity approx. 2% and vice versa.

A change in evaporating temperature t_e changes valve capacity; see correction factor table.

Correction factors

When sizing valves, the required capacity Hot gas must be multiplied by a correction factor depending on evaporating temperature t_e .

Correction factors for evaporating temperature t_e

t_e [°C]	-40	-30	-20	-10	0	10	15
R410A	0.93	0.95	0.98	1.00	1.02	1.03	1.04

**Extended capacity
Hot gas**
(continued)

Type	Pressure drop across valve Δp bar	Hot gas capacity Qh [kW]. Evaporating temp. $t_e = -10.0$ [°C]. Hot gas temp. $t_h = t_c + 25.0$ [K]. Subcooling $\Delta t_{sub} = 4.0$ [K]				
		Condensing temperature t_c [°C]				
		20	30	40	50	60
R410A (continued)						
EVR 25	0.2	50.59	53.17	54.79	55.05	53.21
	0.3	61.69	64.91	66.93	67.29	65.06
	0.4	70.93	74.70	77.09	77.55	75.01
	0.8	98.59	104.26	107.91	108.79	105.40
	1.6	134.55	143.52	149.46	151.36	147.13
EVR 32	0.2	86.45	90.86	93.62	94.08	90.92
	0.3	105.43	110.92	114.37	115.00	111.18
	0.4	121.22	127.66	131.73	132.52	128.18
	0.8	168.48	178.16	184.40	185.91	180.11
	1.6	229.93	245.26	255.41	258.66	251.43
EVR 40	0.2	125.05	131.43	135.43	136.09	131.52
	0.3	152.50	160.44	165.44	166.34	160.82
	0.4	175.34	184.66	190.55	191.69	185.41
	0.8	243.70	257.72	266.74	268.92	260.53
	1.6	332.59	354.78	369.46	374.15	363.69

An increase in hot gas temperature t_h of 10 K, based on $t_h = t_c + 25$ °C, reduces valve capacity approx. 2% and vice versa.

A change in evaporating temperature t_e changes valve capacity; see correction factor table.

Correction factors

When sizing valves, the required capacity Hot gas must be multiplied by a correction factor depending on evaporating temperature t_e .

Correction factors for evaporating temperature t_e

t_e [°C]	-40	-30	-20	-10	0	10	15
R410A	0.93	0.95	0.98	1.00	1.02	1.03	1.04

**Extended capacity
Hot gas**
(continued)

Type	Pressure drop across valve Δp bar	Hot gas capacity Qh [kW]. Evaporating temp. $t_e = -10.0$ [°C]. Hot gas temp. $t_h = t_c + 25.0$ [K]. Subcooling $\Delta t_{sub} = 4.0$ [K]				
		Condensing temperature t_c [°C]				
		20	30	40	50	60
R32						
EVR 2	0.1	0.69	0.74	0.78	0.81	0.82
	0.2	0.97	1.04	1.10	1.15	1.16
	0.3	1.19	1.28	1.35	1.40	1.42
	0.4	1.37	1.47	1.55	1.61	1.64
	0.8	1.90	2.05	2.18	2.27	2.31
	1.6	2.61	2.83	3.02	3.16	3.22
EVR 3	0.1	1.24	1.33	1.41	1.46	1.48
	0.2	1.75	1.88	1.99	2.06	2.09
	0.3	2.14	2.30	2.43	2.52	2.56
	0.4	2.46	2.64	2.79	2.90	2.95
	0.8	3.43	3.69	3.92	4.08	4.15
	1.6	4.69	5.10	5.43	5.68	5.80
EVR 4	0.1	3.14	3.36	3.54	3.68	3.73
	0.2	4.42	4.73	5.00	5.19	5.27
	0.3	5.39	5.78	6.11	6.35	6.45
	0.4	6.20	6.66	7.04	7.32	7.43
	0.8	8.63	9.30	9.86	10.27	10.45
	1.6	11.81	12.83	13.68	14.31	14.61
EVR 6	0.1	4.10	4.39	4.64	4.81	4.89
	0.2	5.78	6.20	6.54	6.80	6.90
	0.3	7.05	7.57	8.00	8.31	8.44
	0.4	8.11	8.71	9.21	9.58	9.73
	0.8	11.29	12.17	12.91	13.44	13.68
	1.6	15.46	16.80	17.91	18.73	19.12
EVR 8	0.1	4.89	5.23	5.52	5.73	5.82
	0.2	6.89	7.38	7.79	8.09	8.22
	0.3	8.40	9.01	9.52	9.89	10.05
	0.4	9.66	10.38	10.97	11.40	11.59
	0.8	13.45	14.50	15.37	16.01	16.29
	1.6	18.41	20.00	21.33	22.31	22.77

An increase in hot gas temperature t_h of 10 K, based on $t_h = t_c + 25$ °C, reduces valve capacity approx. 2% and vice versa.

A change in evaporating temperature t_e changes valve capacity; see correction factor table.

Correction factors

When sizing valves, the required capacity Hot gas must be multiplied by a correction factor depending on evaporating temperature t_e .

Correction factors for evaporating temperature t_e

t_e [°C]	-40	-30	-20	-10	0	10	15
R32	0.96	0.97	0.99	1.00	1.01	1.01	1.01

**Extended capacity
Hot gas**
(continued)

Type	Pressure drop across valve Δp bar	Hot gas capacity Qh [kW]. Evaporating temp. $t_e = -10.0$ [°C]. Hot gas temp. $t_h = t_c + 25.0$ [K]. Subcooling $\Delta t_{sub} = 4.0$ [K]				
		Condensing temperature t_c [°C]				
		20	30	40	50	60
R32 (continued)						
EVR 10	0.1	8.62	9.23	9.75	10.11	10.27
	0.2	12.15	13.02	13.75	14.28	14.50
	0.3	14.82	15.90	16.80	17.45	17.73
	0.4	17.04	18.30	19.36	20.12	20.45
	0.8	23.72	25.57	27.12	28.24	28.75
	1.6	32.48	35.29	37.63	39.35	40.17
EVR 15	0.1	13.28	14.22	15.01	15.58	15.81
	0.2	18.71	20.05	21.18	21.99	22.33
	0.3	22.82	24.49	25.88	26.88	27.31
	0.4	26.25	28.19	29.81	30.98	31.49
	0.8	36.54	39.39	41.77	43.50	44.27
	1.6	50.02	54.35	57.96	60.61	61.87
EVR 18	0.1	17.38	18.62	19.65	20.39	20.70
	0.2	24.49	26.25	27.72	28.79	29.23
	0.3	29.88	32.05	33.87	35.19	35.75
	0.4	34.36	36.90	39.02	40.56	41.22
	0.8	47.83	51.56	54.67	56.94	57.95
	1.6	65.48	71.14	75.87	79.33	80.99
EVR 20	0.1	27.57	29.53	31.17	32.34	32.84
	0.2	38.84	41.64	43.97	45.66	46.37
	0.3	47.39	50.84	53.73	55.82	56.71
	0.4	54.50	58.53	61.90	64.34	65.38
	0.8	75.87	81.79	86.72	90.32	91.93
	1.6	103.86	112.85	120.34	125.84	128.47
EVR 22	0.1	31.45	33.68	35.54	36.89	37.45
	0.2	44.30	47.49	50.15	52.07	52.88
	0.3	54.05	57.99	61.28	63.66	64.67
	0.4	62.16	66.76	70.59	73.37	74.57
	0.8	86.52	93.27	98.91	103.00	104.84
	1.6	118.45	128.70	137.24	143.52	146.52

An increase in hot gas temperature t_h of 10 K, based on $t_h = t_c + 25$ °C, reduces valve capacity approx. 2% and vice versa.

A change in evaporating temperature t_e changes valve capacity; see correction factor table.

Correction factors

When sizing valves, the required capacity Hot gas must be multiplied by a correction factor depending on evaporating temperature t_e .

Correction factors for evaporating temperature t_e

t_e [°C]	-40	-30	-20	-10	0	10	15
R32	0.96	0.97	0.99	1.00	1.01	1.01	1.01

**Extended capacity
Hot gas**
(continued)

Type	Pressure drop across valve Δp bar	Hot gas capacity Qh [kW]. Evaporating temp. $t_e = -10.0$ [°C]. Hot gas temp. $t_h = t_c + 25.0$ [K]. Subcooling $\Delta t_{sub} = 4.0$ [K]				
		Condensing temperature t_c [°C]				
		20	30	40	50	60
R290						
EVR 2	0.1	0.53	0.55	0.56	0.56	0.55
	0.2	0.74	0.77	0.79	0.79	0.77
	0.3	0.90	0.94	0.96	0.97	0.94
	0.4	1.03	1.08	1.11	1.11	1.08
	0.8	1.41	1.49	1.54	1.55	1.52
	1.6	1.87	2.00	2.09	2.12	2.09
EVR 3	0.1	0.95	0.99	1.01	1.01	0.98
	0.2	1.33	1.39	1.42	1.42	1.39
	0.3	1.62	1.69	1.73	1.74	1.70
	0.4	1.86	1.94	1.99	2.00	1.95
	0.8	2.54	2.68	2.76	2.78	2.73
	1.6	3.37	3.60	3.76	3.82	3.76
EVR 4	0.1	2.39	2.49	2.54	2.54	2.48
	0.2	3.36	3.50	3.58	3.59	3.50
	0.3	4.08	4.26	4.36	4.38	4.27
	0.4	4.67	4.89	5.02	5.03	4.92
	0.8	6.40	6.75	6.96	7.01	6.87
	1.6	8.48	9.08	9.47	9.62	9.48
EVR 6	0.1	3.13	3.26	3.33	3.33	3.25
	0.2	4.39	4.58	4.69	4.69	4.58
	0.3	5.34	5.58	5.71	5.73	5.59
	0.4	6.12	6.40	6.57	6.59	6.44
	0.8	8.38	8.84	9.11	9.18	8.99
	1.6	11.09	11.88	12.39	12.58	12.40
EVR 8	0.1	3.73	3.88	3.96	3.97	3.87
	0.2	5.23	5.45	5.58	5.59	5.45
	0.3	6.36	6.64	6.80	6.82	6.66
	0.4	7.29	7.62	7.82	7.85	7.66
	0.8	9.98	10.52	10.85	10.93	10.71
	1.6	13.21	14.15	14.76	14.99	14.77

An increase in hot gas temperature t_h of 10 K, based on $t_h = t_c + 25$ °C, reduces valve capacity approx. 2% and vice versa.

A change in evaporating temperature t_e changes valve capacity; see correction factor table.

Correction factors

When sizing valves, the required capacity Hot gas must be multiplied by a correction factor depending on evaporating temperature t_e .

Correction factors for evaporating temperature t_e

t_e [°C]	-40	-30	-20	-10	0	10	15
R290	0.88	0.92	0.96	1.00	1.04	1.07	1.09

**Extended capacity
Hot gas**
(continued)

Type	Pressure drop across valve Δp bar	Hot gas capacity Qh [kW]. Evaporating temp. $t_e = -10.0$ [°C]. Hot gas temp. $t_h = t_c + 25.0$ [K]. Subcooling $\Delta t_{sub} = 4.0$ [K]				
		Condensing temperature t_c [°C]				
		20	30	40	50	60
R290 (continued)						
EVR 10	0.1	6.58	6.84	6.99	7.00	6.82
	0.2	9.23	9.62	9.85	9.86	9.62
	0.3	11.22	11.72	12.00	12.03	11.74
	0.4	12.85	13.45	13.79	13.84	13.52
	0.8	17.61	18.56	19.14	19.28	18.89
	1.6	23.31	24.97	26.04	26.44	26.06
EVR 15	0.1	10.13	10.54	10.77	10.78	10.51
	0.2	14.22	14.82	15.16	15.19	14.81
	0.3	17.28	18.04	18.48	18.53	18.09
	0.4	19.80	20.71	21.24	21.32	20.82
	0.8	27.13	28.59	29.48	29.70	29.09
	1.6	35.90	38.45	40.10	40.72	40.14
EVR 18	0.1	13.26	13.80	14.10	14.11	13.75
	0.2	18.61	19.40	19.85	19.88	19.39
	0.3	22.62	23.62	24.20	24.26	23.68
	0.4	25.91	27.11	27.81	27.90	27.26
	0.8	35.51	37.42	38.59	38.87	38.09
	1.6	46.99	50.33	52.49	53.31	52.55
EVR 20	0.1	21.03	21.89	22.37	22.38	21.81
	0.2	29.52	30.77	31.48	31.53	30.76
	0.3	35.87	37.47	38.38	38.48	37.56
	0.4	41.10	43.01	44.11	44.26	43.24
	0.8	56.32	59.36	61.21	61.66	60.41
	1.6	74.54	79.84	83.26	84.56	83.35
EVR 22	0.1	23.98	24.96	25.51	25.52	24.88
	0.2	33.66	35.10	35.91	35.96	35.08
	0.3	40.91	42.73	43.77	43.88	42.83
	0.4	46.88	49.05	50.31	50.48	49.31
	0.8	64.23	67.70	69.81	70.32	68.90
	1.6	85.01	91.05	94.95	96.44	95.06

An increase in hot gas temperature t_h of 10 K, based on $t_h = t_c + 25$ °C, reduces valve capacity approx. 2% and vice versa.

A change in evaporating temperature t_e changes valve capacity; see correction factor table.

Correction factors

When sizing valves, the required capacity Hot gas must be multiplied by a correction factor depending on evaporating temperature t_e .

Correction factors for evaporating temperature t_e

t_e [°C]	-40	-30	-20	-10	0	10	15
R290	0.88	0.92	0.96	1.00	1.04	1.07	1.09

**Extended capacity
Hot gas**
(continued)

Type	Pressure drop across valve Δp bar	Hot gas capacity Qh [kW]. Evaporating temp. $t_e = -10.0$ [°C]. Hot gas temp. $t_h = t_c + 25.0$ [K]. Subcooling $\Delta t_{sub} = 4.0$ [K]				
		Condensing temperature t_c [°C]				
		20	30	40	50	60
R600a						
EVR 2	0.1	0.33	0.35	0.37	0.37	0.37
	0.2	0.46	0.49	0.51	0.52	0.52
	0.3	0.55	0.59	0.62	0.63	0.63
	0.4	0.62	0.67	0.70	0.72	0.73
	0.8	0.79	0.88	0.94	0.98	1.00
	1.6	0.89	1.06	1.19	1.28	1.32
EVR 3	0.1	0.60	0.63	0.66	0.67	0.67
	0.2	0.82	0.88	0.92	0.94	0.94
	0.3	0.99	1.06	1.11	1.14	1.14
	0.4	1.11	1.20	1.27	1.30	1.31
	0.8	1.43	1.58	1.70	1.77	1.79
	1.6	1.60	1.91	2.14	2.30	2.37
EVR 4	0.1	1.50	1.59	1.66	1.69	1.68
	0.2	2.07	2.22	2.32	2.37	2.36
	0.3	2.48	2.67	2.80	2.87	2.87
	0.4	2.80	3.03	3.19	3.28	3.29
	0.8	3.59	3.99	4.28	4.46	4.51
	1.6	4.02	4.81	5.40	5.79	5.97
EVR 6	0.1	1.96	2.08	2.17	2.21	2.20
	0.2	2.71	2.90	3.03	3.10	3.09
	0.3	3.25	3.49	3.67	3.76	3.76
	0.4	3.67	3.97	4.18	4.30	4.31
	0.8	4.70	5.22	5.61	5.84	5.90
	1.6	5.27	6.30	7.07	7.58	7.82
EVR 8	0.1	2.34	2.48	2.58	2.63	2.62
	0.2	3.23	3.45	3.61	3.69	3.68
	0.3	3.87	4.16	4.37	4.48	4.48
	0.4	4.37	4.72	4.98	5.12	5.13
	0.8	5.60	6.22	6.68	6.95	7.03
	1.6	6.27	7.50	8.42	9.03	9.31

An increase in hot gas temperature t_h of 10 K, based on $t_h = t_c + 25$ °C, reduces valve capacity approx. 2% and vice versa.

A change in evaporating temperature t_e changes valve capacity; see correction factor table.

Correction factors

When sizing valves, the required capacity Hot gas must be multiplied by a correction factor depending on evaporating temperature t_e .

Correction factors for evaporating temperature t_e

t_e [°C]	-40	-30	-20	-10	0	10	15
R600a	0.86	0.91	0.95	1.00	1.05	1.10	1.12

**Extended capacity
Hot gas**
(continued)

Type	Pressure drop across valve Δp bar	Hot gas capacity Qh [kW]. Evaporating temp. $t_e = -10.0$ [°C]. Hot gas temp. $t_h = t_c + 25.0$ [K]. Subcooling $\Delta t_{sub} = 4.0$ [K]				
		Condensing temperature t_c [°C]				
		20	30	40	50	60
R600a (continued)						
EVR 10	0.1	4.12	4.38	4.56	4.65	4.63
	0.2	5.70	6.09	6.37	6.51	6.50
	0.3	6.83	7.34	7.70	7.90	7.90
	0.4	7.70	8.33	8.78	9.03	9.05
	0.8	9.87	10.98	11.78	12.26	12.41
	1.6	11.07	13.24	14.85	15.92	16.43
EVR 15	0.1	6.35	6.75	7.02	7.16	7.13
	0.2	8.78	9.39	9.81	10.03	10.01
	0.3	10.52	11.30	11.86	12.16	12.16
	0.4	11.87	12.83	13.52	13.90	13.94
	0.8	15.20	16.91	18.14	18.89	19.11
	1.6	17.04	20.39	22.88	24.52	25.30
EVR 18	0.1	8.31	8.83	9.19	9.37	9.33
	0.2	11.50	12.29	12.84	13.12	13.10
	0.3	13.77	14.80	15.53	15.92	15.92
	0.4	15.53	16.80	17.70	18.20	18.25
	0.8	19.90	22.13	23.75	24.73	25.01
	1.6	22.31	26.69	29.95	32.10	33.12
EVR 20	0.1	13.19	14.01	14.58	14.86	14.81
	0.2	18.24	19.49	20.37	20.82	20.78
	0.3	21.84	23.47	24.63	25.25	25.26
	0.4	24.64	26.65	28.08	28.87	28.94
	0.8	31.57	35.10	37.67	39.22	39.67
	1.6	35.39	42.33	47.50	50.92	52.54
EVR 22	0.1	15.04	15.98	16.63	16.95	16.89
	0.2	20.80	22.23	23.23	23.74	23.70
	0.3	24.91	26.77	28.09	28.80	28.81
	0.4	28.10	30.39	32.02	32.93	33.01
	0.8	36.00	40.03	42.96	44.73	45.24
	1.6	40.36	48.28	54.18	58.07	59.92

An increase in hot gas temperature t_h of 10 K, based on $t_h = t_c + 25$ °C, reduces valve capacity approx. 2% and vice versa.

A change in evaporating temperature t_e changes valve capacity; see correction factor table.

Correction factors

When sizing valves, the required capacity Hot gas must be multiplied by a correction factor depending on evaporating temperature t_e .

Correction factors for evaporating temperature t_e

t_e [°C]	-40	-30	-20	-10	0	10	15
R600a	0.86	0.91	0.95	1.00	1.05	1.10	1.12

**Extended capacity
Hot gas**
(continued)

Type	Condensing temperature t_c [°C]	Hot gas capacity G_h [kg/h] at pressure drop across valve Δp [bar]								
		Hot gas temperature $t_h = 60^\circ\text{C}$								
		0.5	1	2	3	4	5	6	7	8
R22/R407C										
EVR 2	25	20	27	36	41	44	46	46	46	46
	35	23	32	43	50	55	58	60	61	61
	45	27	38	51	60	67	72	75	78	79
EVR 3	25	35	49	65	74	79	82	83	83	83
	35	42	57	77	90	99	104	108	109	110
	45	49	68	92	109	120	129	136	140	143
EVR 4	25	89	123	163	186	200	207	208	208	208
	35	105	145	195	227	249	263	272	276	276
	45	123	170	232	273	303	325	341	352	359
EVR 6	25	117	160	213	244	262	270	272	272	272
	35	137	189	255	297	326	344	356	361	361
	45	160	223	304	358	397	426	447	461	470
EVR 8	25	139	191	254	290	312	322	324	324	324
	35	163	226	304	354	388	410	423	430	430
	45	191	265	362	426	473	507	532	549	560
EVR 10	25	246	337	447	512	550	568	572	572	572
	35	288	398	536	625	684	724	747	758	759
	45	337	468	638	752	834	895	939	969	988
EVR 15	25	378	519	689	788	847	875	881	881	881
	35	443	613	826	962	1054	1114	1151	1167	1169
	45	519	721	983	1158	1285	1378	1446	1493	1522
EVR 18	25	495	679	902	1032	1108	1146	1153	1153	1153
	35	581	802	1082	1260	1380	1459	1506	1528	1530
	45	679	944	1286	1516	1682	1804	1893	1954	1992
EVR 20	25	785	1078	1430	1637	1758	1817	1830	1830	1830
	35	921	1273	1716	1998	2188	2314	2389	2423	2427
	45	1078	1497	2040	2405	2669	2862	3003	3100	3160
EVR 22	25	896	1229	1631	1867	2005	2072	2087	2087	2087
	35	1050	1451	1957	2279	2496	2639	2725	2764	2768
	45	1229	1707	2327	2743	3043	3264	3424	3535	3604
EVR 25	25	1286	1764	2342	2680	2878	2975	2995	2995	2995
	35	1508	2083	2809	3271	3583	3788	3911	3967	3973
	45	1764	2451	3340	3937	4369	4686	4916	5074	5174
EVR 32	25	2197	3015	4002	4580	4918	5084	5119	5119	5119
	35	2576	3560	4800	5590	6122	6473	6684	6779	6790
	45	3015	4188	5708	6728	7466	8008	8400	8672	8841
EVR 40	25	3179	4361	5789	6625	7114	7354	7404	7404	7404
	35	3726	5150	6943	8086	8856	9364	9668	9806	9821
	45	4361	6058	8257	9732	10799	11583	12151	12544	12789

An increase in hot gas temperature t_h of 10 K, based on $t_h = t_c + 25^\circ\text{C}$, reduces valve capacity approx. 2% and vice versa.

A change in evaporating temperature t_c changes valve capacity.

**Extended capacity
Hot gas**
(continued)

Type	Condensing temperature t_c [°C]	Hot gas capacity G_h [kg/h] at pressure drop across valve Δp [bar]								
		Hot gas temperature $t_h = 60^\circ \text{C}$								
		0.5	1	2	3	4	5	6	7	8
R134a										
EVR 2	25	17	22	28	30	31	31	31	–	–
	35	20	27	35	39	41	42	42	42	42
	45	24	32	43	49	53	55	56	56	56
EVR 3	25	30	40	51	55	55	55	55	–	–
	35	36	49	63	71	74	75	75	75	75
	45	42	58	77	89	96	100	101	101	101
EVR 4	25	75	101	128	138	139	139	139	–	–
	35	90	122	159	179	187	189	189	189	189
	45	107	146	195	224	241	251	254	254	254
EVR 6	25	99	132	167	180	182	182	182	–	–
	35	118	160	209	234	245	247	247	247	247
	45	140	192	255	293	316	328	332	332	332
EVR 8	25	117	158	199	215	216	216	216	–	–
	35	140	191	248	279	292	294	294	294	294
	45	166	228	304	349	376	391	395	395	395
EVR 10	25	207	278	351	379	381	381	381	–	–
	35	247	336	438	491	515	519	519	519	519
	45	293	403	536	616	664	690	698	698	698
EVR 15	25	319	428	541	583	587	587	587	–	–
	35	380	518	675	757	793	799	799	799	799
	45	451	620	826	948	1023	1062	1074	1074	1074
EVR 18	25	417	560	708	764	769	769	769	–	–
	35	498	678	884	991	1038	1046	1046	1046	1046
	45	591	812	1081	1242	1339	1390	1406	1406	1406
EVR 20	25	662	889	1123	1211	1220	1220	1220	–	–
	35	790	1075	1402	1572	1647	1658	1658	1658	1658
	45	937	1288	1715	1969	2123	2205	2231	2231	2231
EVR 22	25	755	1014	1281	1381	1391	1391	1391	–	–
	35	901	1226	1599	1792	1879	1891	1891	1891	1891
	45	1069	1469	1956	2246	2421	2515	2544	2544	2544
EVR 25	25	1084	1455	1838	1983	1997	1997	1997	–	–
	35	1293	1760	2295	2573	2697	2715	2715	2715	2715
	45	1535	2108	2807	3224	3476	3610	3652	3652	3652
EVR 32	25	1852	2487	3142	3388	3412	3412	3412	–	–
	35	2210	3008	3922	4397	4608	4640	4640	4640	4640
	45	2622	3603	4797	5510	5940	6169	6241	6242	6242
EVR 40	25	2679	3597	4545	4901	4935	4935	4935	–	–
	35	3196	4350	5673	6360	6666	6712	6712	6712	6712
	45	3793	5212	6939	7970	8592	8924	9028	9028	9028

An increase in hot gas temperature t_h of 10 K, based on $t_h = t_c + 25^\circ \text{C}$, reduces valve capacity approx. 2% and vice versa.

A change in evaporating temperature t_e changes valve capacity.

**Extended capacity
Hot gas**
(continued)

Type	Condensing temperature t_c [°C]	Hot gas capacity G_h [kg/h] at pressure drop across valve Δp [bar]								
		Hot gas temperature $t_h = 60^\circ \text{C}$								
		0.5	1	2	3	4	5	6	7	8
R404A/R507										
EVR 2	25	24	33	44	50	55	57	58	59	59
	35	28	39	52	61	68	72	75	77	78
	45	33	46	63	75	83	90	95	98	101
EVR 3	25	43	59	78	91	98	103	105	105	105
	35	50	70	94	111	122	130	135	139	140
	45	60	83	114	134	150	162	171	177	182
EVR 4	25	107	148	198	228	248	259	265	265	265
	35	126	175	238	278	307	327	341	349	353
	45	150	209	286	339	378	407	430	446	458
EVR 6	25	140	193	259	299	324	339	346	347	347
	35	165	229	311	364	402	428	446	457	462
	45	196	273	374	443	494	533	562	584	600
EVR 8	25	167	230	308	356	386	404	412	414	414
	35	197	273	370	434	479	510	531	544	550
	45	234	326	446	528	589	635	670	696	714
EVR 10	25	295	406	543	628	681	713	728	730	730
	35	348	482	653	766	844	900	937	960	970
	45	413	574	786	931	1038	1120	1181	1227	1260
EVR 15	25	454	625	837	967	1049	1098	1120	1124	1124
	35	535	742	1006	1179	1301	1386	1444	1479	1494
	45	636	885	1211	1434	1599	1725	1820	1890	1941
EVR 18	25	594	818	1095	1265	1373	1437	1467	1471	1471
	35	701	971	1317	1544	1703	1814	1890	1935	1956
	45	832	1158	1585	1877	2093	2257	2382	2474	2540
EVR 20	25	942	1298	1737	2007	2178	2280	2327	2333	2333
	35	1111	1540	2089	2448	2701	2878	2997	3070	3103
	45	1320	1837	2515	2978	3321	3581	3778	3925	4029
EVR 22	25	1075	1480	1981	2289	2484	2600	2653	2661	2661
	35	1268	1757	2382	2792	3080	3282	3418	3501	3539
	45	1505	2095	2868	3396	3787	4084	4309	4476	4595
EVR 25	25	1543	2125	2844	3285	3566	3732	3809	3819	3819
	35	1820	2521	3419	4008	4421	4711	4907	5026	5080
	45	2161	3008	4117	4875	5436	5862	6185	6426	6597
EVR 32	25	2636	3631	4860	5614	6094	6377	6509	6527	6527
	35	3110	4309	5843	6850	7555	8051	8385	8589	8681
	45	3692	5140	7035	8331	9290	10018	10570	10981	11273
EVR 40	25	3814	5252	7029	8121	8814	9225	9415	9441	9441
	35	4498	6233	8452	9908	10929	11646	12130	12424	12557
	45	5341	7434	10176	12051	13438	14491	15290	15884	16306

An increase in hot gas temperature t_h of 10 K, based on $t_h = t_c + 25^\circ \text{C}$, reduces valve capacity approx. 2% and vice versa.

A change in evaporating temperature t_c changes valve capacity.

**Extended capacity
Hot gas**
(continued)

Type	Condensing temperature t_c °C]	Hot gas capacity G_h [kg/h] at pressure drop across valve Δp [bar]								
		Hot gas temperature $t_h = 60^\circ \text{C}$								
		0.5	1	2	3	4	5	6	7	8
R410A										
EVR 2	25	24	33	45	52	58	62	65	67	68
	35	28	39	53	63	71	77	81	85	87
	45	33	46	64	77	86	94	101	106	110
EVR 3	25	42	59	80	94	104	112	117	120	122
	35	50	70	96	114	128	138	146	152	157
	45	60	84	115	138	156	170	181	191	198
EVR 4	25	107	148	202	237	263	281	294	302	307
	35	126	176	242	287	321	347	368	384	396
	45	150	210	291	348	392	427	456	480	500
EVR 6	25	140	194	264	311	344	368	384	396	402
	35	165	230	316	376	420	455	482	502	518
	45	197	275	381	455	513	559	597	629	654
EVR 8	25	167	231	315	370	409	438	458	471	479
	35	197	274	377	447	501	542	574	598	617
	45	235	328	453	542	611	666	711	749	779
EVR 10	25	294	408	555	652	722	772	808	831	844
	35	347	484	665	789	883	956	1012	1055	1088
	45	414	579	800	956	1078	1175	1255	1321	1374
EVR 15	25	453	628	855	1005	1112	1190	1244	1280	1300
	35	535	746	1024	1216	1360	1472	1559	1626	1676
	45	637	891	1231	1473	1660	1810	1933	2034	2117
EVR 18	25	593	822	1119	1315	1456	1557	1629	1676	1702
	35	700	976	1340	1592	1780	1927	2040	2128	2194
	45	834	1166	1612	1928	2173	2370	2530	2663	2771
EVR 20	25	940	1305	1774	2086	2309	2470	2583	2658	2700
	35	1111	1548	2125	2524	2824	3056	3236	3375	3480
	45	1323	1850	2557	3058	3446	3759	4014	4223	4395
EVR 22	25	1072	1488	2024	2380	2634	2817	2946	3032	3080
	35	1267	1766	2424	2879	3221	3485	3691	3849	3969
	45	1509	2110	2916	3488	3931	4287	4578	4817	5013
EVR 25	25	1539	2136	2905	3416	3781	4044	4229	4352	4421
	35	1819	2535	3480	4133	4623	5003	5298	5526	5697
	45	2166	3029	4186	5006	5642	6153	6571	6914	7196
EVR 32	25	2630	3650	4964	5837	6461	6910	7227	7437	7554
	35	3108	4332	5946	7063	7901	8549	9054	9443	9735
	45	3702	5176	7153	8555	9642	10515	11229	11816	12297
EVR 40	25	3805	5279	7180	8444	9345	9996	10455	10757	10928
	35	4496	6266	8601	10216	11429	12367	13096	13659	14082
	45	5355	7487	10347	12375	13947	15211	16243	17091	17787

An increase in hot gas temperature t_h of 10 K, based on $t_h = t_c + 25^\circ \text{C}$, reduces valve capacity approx. 2% and vice versa.

A change in evaporating temperature t_e changes valve capacity.

**Extended capacity
Hot gas**
(continued)

Type	Condensing temperature t_c [°C]	Hot gas capacity G_h [kg/h] at pressure drop across valve Δp [bar]								
		Hot gas temperature $t_h = 60^\circ \text{C}$								
		0.5	1	2	3	4	5	6	7	8
R32										
EVR 2	25	20	28	38	45	49	52	54	55	56
	35	24	33	45	54	60	65	69	71	73
	45	28	39	54	65	73	80	85	90	93
EVR 3	25	36	50	68	80	89	94	98	100	100
	35	43	60	82	97	109	117	124	128	132
	45	51	71	98	117	132	144	154	161	167
EVR 4	25	107	150	204	240	265	282	292	298	298
	35	126	178	244	290	324	350	369	383	393
	45	149	212	293	350	394	430	458	481	499
EVR 6	25	125	177	240	282	311	331	344	350	351
	35	148	209	287	341	381	412	434	451	462
	45	175	249	344	412	464	505	539	566	587
EVR 8	25	166	234	318	374	413	439	456	464	465
	35	196	277	381	452	505	545	576	598	612
	45	232	330	456	546	615	670	714	750	778
EVR 10	25	260	365	496	582	643	684	710	723	724
	35	306	432	593	704	787	850	897	931	954
	45	363	514	711	850	958	1043	1112	1168	1212
EVR 15	25	401	559	761	893	986	1049	1089	1108	1111
	35	473	662	910	1080	1207	1303	1375	1428	1463
	45	561	788	1090	1304	1469	1600	1706	1792	1859
EVR 18	25	493	690	938	1102	1216	1294	1344	1368	1371
	35	582	817	1122	1333	1489	1608	1697	1762	1805
	45	690	973	1345	1608	1812	1974	2105	2210	2293
EVR 20	25	804	1133	1540	1809	1996	2125	2206	2245	2251
	35	948	1342	1843	2188	2445	2639	2786	2892	2963
	45	1125	1597	2207	2640	2975	3241	3456	3629	3765
EVR 22	25	916	1273	1737	2050	2278	2447	2571	2659	2717
	35	1080	1507	2074	2470	2771	3008	3196	3345	3462
	45	1281	1792	2482	2975	3360	3673	3932	4148	4328

An increase in hot gas temperature t_h of 10 K, based on $t_h = t_c + 25^\circ \text{C}$, reduces valve capacity approx. 2% and vice versa.

A change in evaporating temperature t_e changes valve capacity.

**Extended capacity
Hot gas**
(continued)

Type	Condensing temperature t_c [°C]	Hot gas capacity G_h [kg/h] at pressure drop across valve Δp [bar]								
		Hot gas temperature $t_h = 60^\circ\text{C}$								
		0.5	1	2	3	4	5	6	7	8
R290										
EVR 2	25	13	18	24	27	29	29	29	29	29
	35	16	22	29	33	36	38	38	38	38
	45	18	25	34	40	44	47	48	49	50
EVR 3	25	24	33	43	49	52	53	53	53	53
	35	28	39	52	60	65	68	69	69	69
	45	33	45	61	72	79	84	87	89	90
EVR 4	25	61	83	109	124	131	133	133	133	133
	35	71	98	130	151	163	171	174	174	174
	45	82	114	155	181	199	212	220	224	226
EVR 6	25	80	109	143	162	171	174	174	174	174
	35	93	128	171	197	214	223	227	228	228
	45	108	149	202	237	260	277	288	294	296
EVR 8	25	95	130	170	193	204	208	208	208	208
	35	110	152	203	235	254	266	271	271	271
	45	129	178	241	282	310	330	342	350	352
EVR 10	25	167	229	300	340	360	366	366	366	366
	35	195	268	359	414	449	469	478	479	479
	45	227	314	425	497	547	582	604	617	622
EVR 15	25	258	352	463	523	554	564	564	564	564
	35	300	413	553	638	691	722	736	737	737
	45	349	483	654	766	843	896	931	950	957
EVR 18	25	337	461	606	685	726	738	738	738	738
	35	393	541	723	835	905	946	963	965	965
	45	457	633	857	1002	1103	1173	1218	1244	1253
EVR 20	25	535	731	960	1087	1151	1171	1171	1171	1171
	35	623	858	1147	1324	1435	1500	1528	1531	1531
	45	725	1004	1359	1590	1750	1860	1932	1973	1988
EVR 22	25	610	834	1095	1239	1313	1335	1335	1335	1335
	35	711	979	1308	1510	1637	1710	1743	1746	1746
	45	827	1145	1550	1813	1995	2121	2204	2250	2267

An increase in hot gas temperature t_h of 10 K, based on $t_h = t_c + 25^\circ\text{C}$, reduces valve capacity approx. 2% and vice versa.

A change in evaporating temperature t_e changes valve capacity.

**Extended capacity
Hot gas**
(continued)

Type	Condensing temperature t_c [°C]	Hot gas capacity G_h [kg/h] at pressure drop across valve Δp [bar]								
		Hot gas temperature $t_h = 60^\circ \text{C}$								
		0.5	1	2	3	4	5	6	7	8
R600a										
EVR 2	25	9	11	12	12	–	–	–	–	–
	35	10	13	16	16	16	–	–	–	–
	45	12	16	20	21	21	21	21	–	–
EVR 3	25	15	19	21	21	–	–	–	–	–
	35	18	24	28	29	29	–	–	–	–
	45	22	29	36	38	38	38	38	–	–
EVR 4	25	39	49	54	54	–	–	–	–	–
	35	46	60	72	72	72	–	–	–	–
	45	55	73	91	96	96	96	96	–	–
EVR 6	25	51	64	71	71	–	–	–	–	–
	35	61	79	94	95	95	–	–	–	–
	45	71	95	119	125	125	125	125	–	–
EVR 8	25	60	77	84	84	–	–	–	–	–
	35	72	94	112	113	113	–	–	–	–
	45	85	113	141	149	149	149	149	–	–
EVR 10	25	106	135	148	148	–	–	–	–	–
	35	127	166	197	199	199	–	–	–	–
	45	150	200	249	263	263	263	263	–	–
EVR 15	25	164	208	228	228	–	–	–	–	–
	35	196	256	303	307	307	–	–	–	–
	45	231	308	384	406	406	406	406	–	–
EVR 18	25	214	272	299	299	–	–	–	–	–
	35	256	335	397	401	401	–	–	–	–
	45	303	404	502	531	531	531	531	–	–
EVR 20	25	340	432	474	474	–	–	–	–	–
	35	407	532	630	637	637	–	–	–	–
	45	480	640	797	842	843	843	843	–	–
EVR 22	25	388	493	541	541	–	–	–	–	–
	35	464	607	719	726	726	–	–	–	–
	45	547	730	908	960	961	961	961	–	–

An increase in hot gas temperature t_h of 10 K, based on $t_h = t_c + 25^\circ \text{C}$, reduces valve capacity approx. 2% and vice versa.

A change in evaporating temperature t_e changes valve capacity.